



© 2006 Lennox Industries Inc.
Dallas, Texas, USA

INSTALLATION INSTRUCTIONS

G50UH(X) Series



GAS FURNACE
505,254M
05/2009
Supersedes 08/2006

TP Technical
Publications
Litho U.S.A.

Table of Contents

Unit Dimensions	2
G50UH(X) Parts Arrangement	3
G50UH(X) Gas Furnace	4
Shipping and Packing List	4
Safety Information	4
Use of Furnace as a Construction Heater	5
General	5
Combustion, Dilution & Ventilation Air	6
Setting Equipment	9
Filters	13
Duct System	13
Venting	13
Gas Piping	21
Electrical	22
Unit Start-Up	26
Gas Pressure Adjustment	27
High Altitude Information	28
Other Unit Adjustments	28
Blower Performance Data	29
Service	33
Planned Service	34
Repair Parts List	35
Ignition Control Board Diagnostic Codes	35
Troubleshooting	36
Start-Up & Performance Check List	40

**RETAIN THESE INSTRUCTIONS
FOR FUTURE REFERENCE**



⚠ WARNING

FIRE OR EXPLOSION HAZARD.

Failure to follow safety warnings exactly could result in serious injury, death, or property damage.



Do not store or use gasoline or other flammable vapors and liquids in the vicinity of this or any other appliance.

Installation and service must be performed by a qualified installer, service agency or the gas supplier.

WHAT TO DO IF YOU SMELL GAS:

- **Do not try to light any appliance.**
- **Do not touch any electrical switch; do not use any phone in your building.**
- **Leave the building immediately.**
- **Immediately call your gas supplier from a neighbor's phone. Follow the gas supplier's instructions.**
- **If you cannot reach your gas supplier, call the fire department.**



G50UH(X) Unit Dimensions - inches (mm)

¹ NOTE - 60C and 60D size units that require air volumes over 1800 cfm (850 L/s) must have one of the following:

1. Single side return air with transition, to accommodate 20 x 25 x 1 in. (508 x 635 x 25 mm) air filter. Required to maintain proper air velocity across the filter.
2. Single side return air with optional RAB Return Air Base
3. Bottom return air.
4. Return air from both sides.
5. Bottom and one side return air.

See Blower Performance Tables for additional information.

² Flue outlet may be horizontal but furnace must be vented vertically

³ Optional External Side Return Air Filter Kit is not for use with the optional RAB Return Air Base.

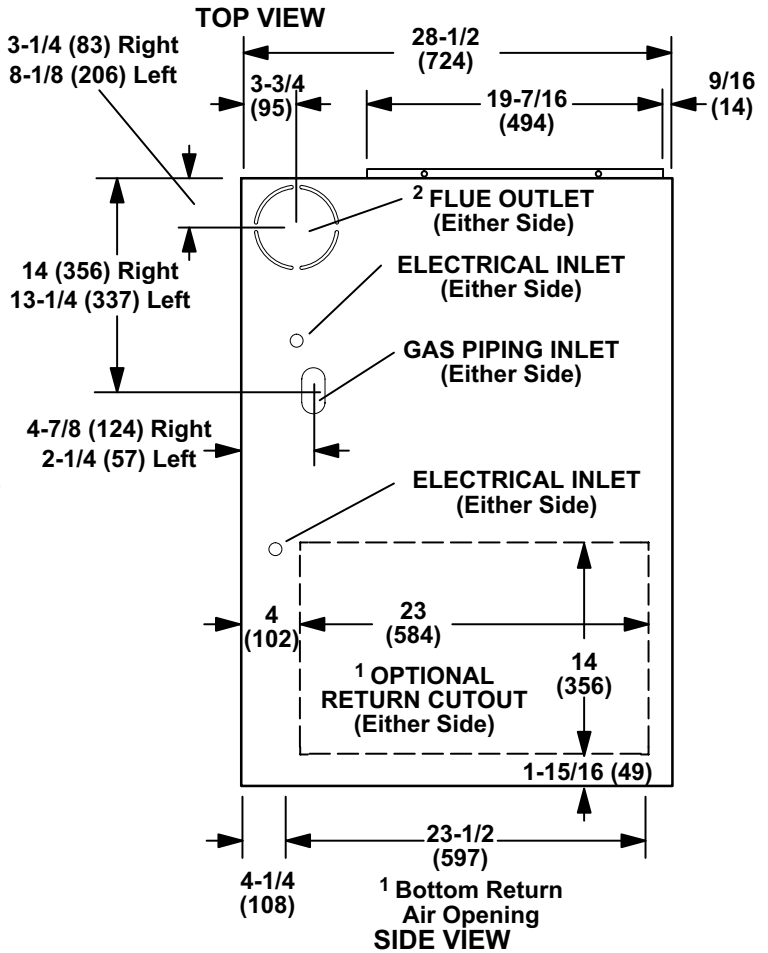
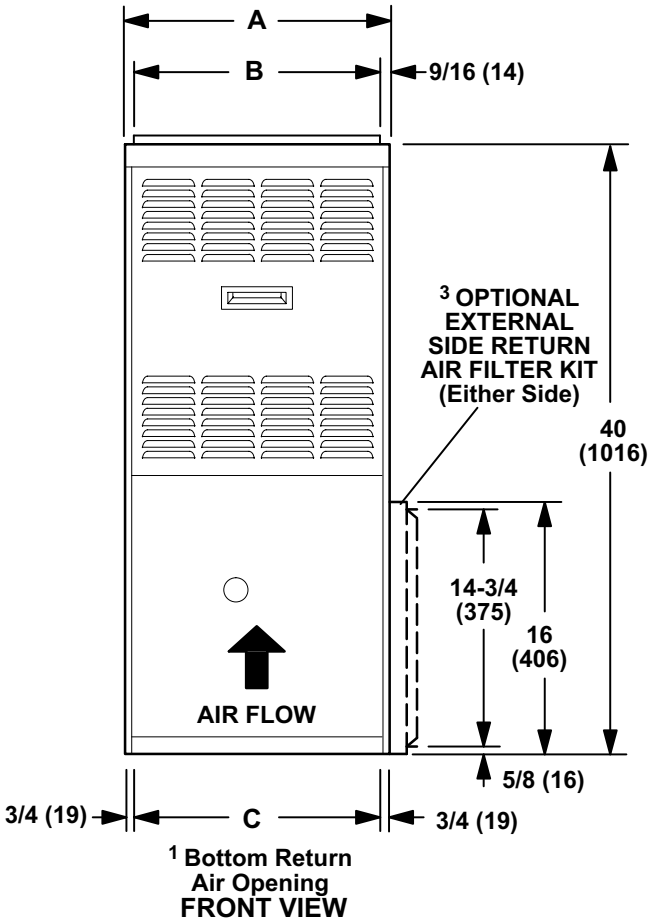
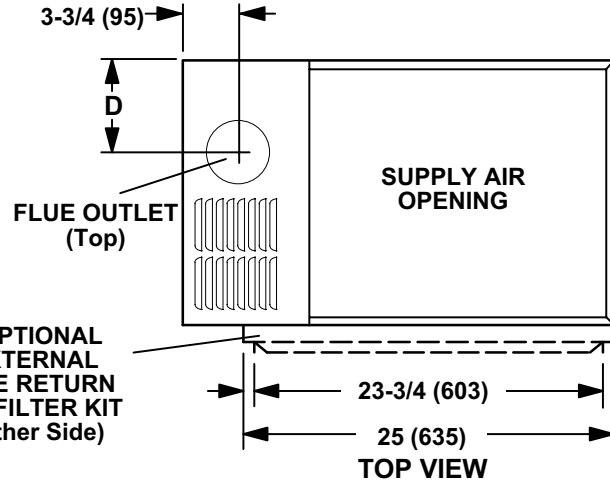

Model No.	A		B		C		D	
	in.	mm	in.	mm	in.	mm	in.	mm
G50UH-24A-045, G50UH-24A-070, G50UH-36A-070	14-1/2	368	13-3/8	340	13	330	4-1/2	114
G50UH-36B-090, G50UH-48B-090	17-1/2	446	16-3/8	416	16	406	6	152
G50UH-36C-110, G50UH-48C-110, G50UH-48C-135, G50UH-60C-110	21	533	19-7/8	504	19-1/2	495	7-3/4	197
G50UH-60D-135, G50UH-60D-155	24-1/2	622	23-3/8	546	23	584	9-1/2	241

G50UH(X) Parts Arrangement

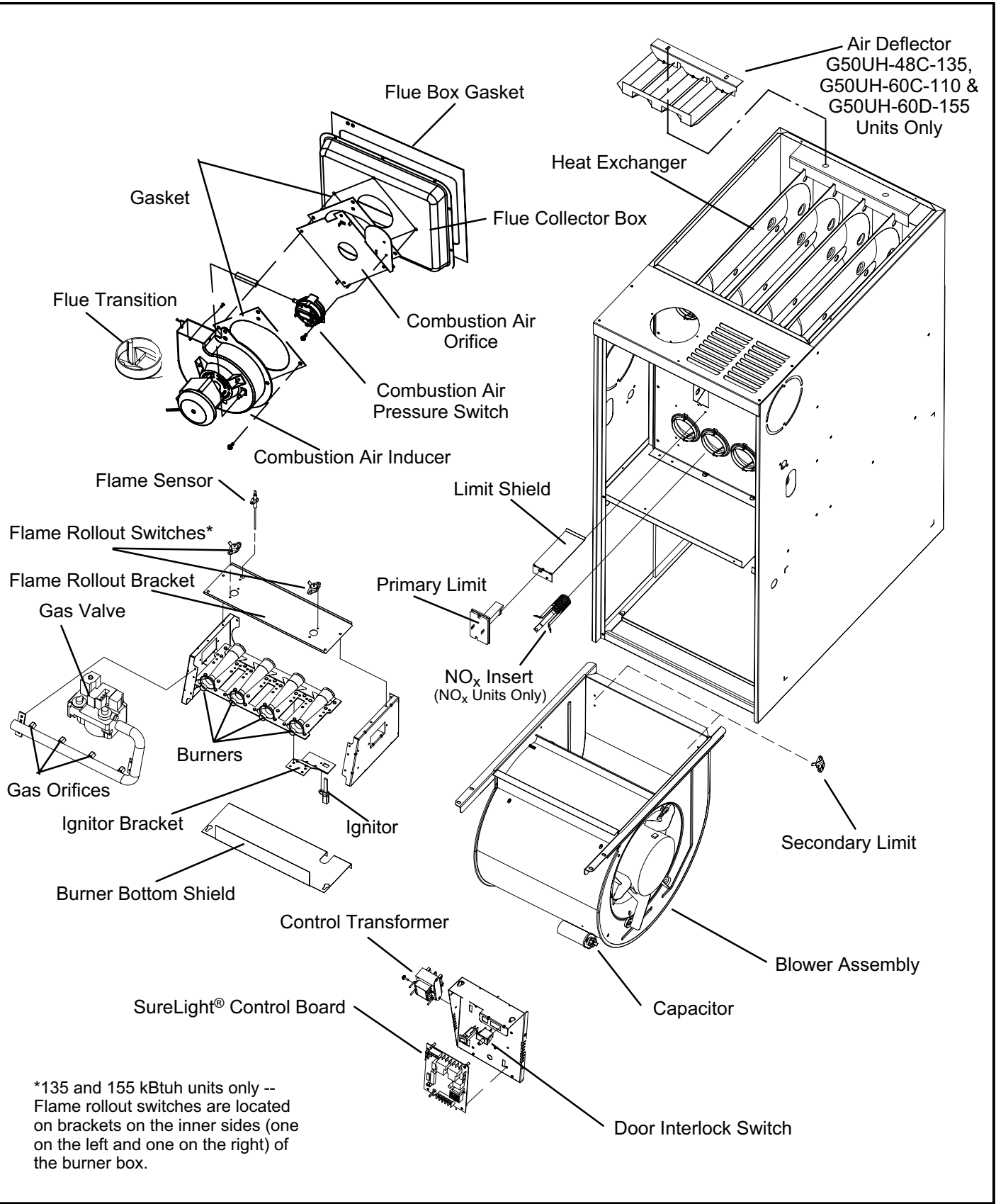

FIGURE 1

G50UH(X) Gas Furnace

The G50UH(X) gas furnace is shipped ready for installation in the upflow or horizontal position (left or right). The furnace is shipped with the bottom panel in place. The bottom panel must be removed if the unit is to be installed in a horizontal application. The panel may also be removed in upflow applications.

Shipping and Packing List

Package 1 of 1 contains

- 1 - Assembled G50UH(X) unit
- 1 - Bag assembly containing the following:
 - 2 - Screws
 - 3 - Wire nuts
 - 1 - Snap bushing
 - 1 - Snap plug
 - 1 - Wire tie
 - 1 - Vent warning label
 - 1 - Owner's manual and warranty card

The following items may be ordered separately:

- 1 - Thermostat
- 1 - Hanging bracket (for horizontal installations)
- 1 - Propane/LP changeover kit
- 1 - High altitude kit
- 1 - Return air base
- 1 - Side filter kit

Check equipment for shipping damage. If you find any damage, immediately contact the last carrier.

⚠ DANGER

Danger of explosion.

There are circumstances in which odorant used with LP/propane gas can lose its scent. In case of a leak, LP/propane gas will settle close to the floor and may be difficult to smell. An LP/propane leak detector should be installed in all LP applications.

Safety Information

⚠ WARNING

Improper installation, adjustment, alteration, service or maintenance can cause property damage, personal injury or loss of life. Installation and service must be performed by a licensed professional installer (or equivalent), service agency or the gas supplier.

⚠ CAUTION

As with any mechanical equipment, personal injury can result from contact with sharp sheet metal edges. Be careful when you handle this equipment.

G50UH(X) units are CSA International certified to ANSI Z21.47 and CSA 2.3 standard.

In the USA, installation of gas furnaces must conform with local building codes. In the absence of local codes, units must be installed according to the current National Fuel Gas Code (ANSI-Z223.1/NFPA 54). The National Fuel Gas Code is available from the following address:

American National Standards Institute, Inc.
11 West 42nd Street
New York, NY 10036

In Canada, installation must conform with current National Standard of Canada CSA B149 Natural Gas and Propane Installation Codes," local plumbing or waste water codes and other applicable local codes.

Adequate clearance must be made around the air openings into the vestibule area. In order to ensure proper unit operation, combustion and ventilation air supply must be provided according to the current National Fuel Gas Code or CSA B149 standards.

Vent installations must be consistent with the venting tables (in this instruction) and applicable provisions of local building codes.

This furnace is CSA International certified for installation clearances to combustible material as listed on the unit nameplate and in the tables in figures 6 and 11. Accessibility and service clearances must take precedence over fire protection clearances.

NOTE - For installation on combustible floors, the furnace shall not be installed directly on carpeting, tile, or other combustible material other than wood flooring.

For installation in a residential garage, the furnace must be installed so that the burner(s) and the ignition source are located no less than 18 inches (457 mm) above the floor. The furnace must be located or protected to avoid physical damage by vehicles. When a furnace is installed in a public garage, hangar, or other building that has a hazardous atmosphere, the furnace must be installed according to recommended good practice requirements and current National Fuel Gas Code or CSA B149 standards.

NOTE - Furnace must be adjusted to obtain a temperature rise within the range specified on the unit nameplate. Failure to do so may cause erratic limit operation.

This G50UH(X) furnace must be installed so that its electrical components are protected from water.

When this furnace is used with cooling units, it shall be installed in parallel with, or on the upstream side of, cooling units to avoid condensation in the heating compartment. With a parallel flow arrangement, a damper (or other means to control the flow of air) must adequately prevent chilled air from entering the furnace. If the damper is manually operated, it must be equipped to prevent operation of either the heating or the cooling unit, unless it is in the full **HEAT** or **COOL** setting.

When installed, this furnace must be electrically grounded according to local codes. In addition, in the United States, installation must conform with the current National Electric Code, ANSI/NFPA No. 70. The National Electric Code (ANSI/NFPA No. 70) is available from the following address:

National Fire Protection Association
1 Battery March Park
Quincy, MA 02269

In Canada, all electrical wiring and grounding for the unit must be installed according to the current regulations of the Canadian Electrical Code Part I (CSA Standard C22.1) and/or local codes.

NOTE - This furnace is designed for a minimum continuous return air temperature of 60°F (16°C) or an intermittent operation down to 55°F (13°C) dry bulb for cases where a night setback thermostat is used. Return air temperature must not exceed 85°F (29°C) dry bulb.

The G50UH(X) furnace may be installed in alcoves, closets, attics, basements, garages, and utility rooms in the up-flow or horizontal position.

This furnace design has not been CSA International certified for installation in mobile homes, recreational vehicles, or outdoors.

Use of Furnace as a Construction Heater

Lennox does not recommend the use of G50UH units as a construction heater during any phase of construction. Very low return air temperatures, harmful vapors and operation of the unit with clogged or misplaced filters will damage the unit.

G50UH units may be used for heating of buildings or structures under construction, if the following conditions are met:

- *The vent system must be permanently installed per these installation instructions.*
- *A room thermostat must control the furnace. The use of fixed jumpers that will provide continuous heating is not allowed.*

- *The return air duct must be provided and sealed to the furnace.*
- *Return air temperature range between 60°F (16°C) and 80°F (27°C) must be maintained.*
- *Air filters must be installed in the system and must be maintained during construction.*
- *Air filters must be replaced upon construction completion.*
- *The input rate and temperature rise must be set per the furnace rating plate.*
- *One hundred percent (100%) outdoor air must be provided for combustion air requirements during construction. Temporary ducting may supply outdoor air to the furnace. Do not connect duct directly to the furnace. Size the temporary duct following these instructions in section for Combustion, Dilution and Ventilation Air in a confined space with air from outside.*
- *The furnace heat exchanger, components, duct system, air filters and evaporator coils must be thoroughly cleaned following final construction clean-up.*
- *All furnace operating conditions (including ignition, input rate, temperature rise and venting) must be verified according to these installation instructions.*

NOTE - The Commonwealth of Massachusetts stipulates these additional requirements:

- **Gas furnaces shall be installed by a licensed plumber or gas fitter only.**
- **The gas cock must be "T handle" type.**
- **When a furnace is installed in an attic, the passageway to and service area surrounding the equipment shall be floored.**

General

These instructions are intended as a general guide and do not supersede local codes in any way. Consult authorities having jurisdiction before installation.

In addition to the requirements outlined previously, the following general recommendations must be considered when installing a G50UH(X) furnace:

- Place the furnace as close to the center of the air distribution system as possible. The furnace should also be located close to the chimney or vent termination point.
- Do not install the furnace where drafts might blow directly into it. This could cause improper combustion and unsafe operation.
- Do not block the furnace combustion air openings with clothing, boxes, doors, etc. Air is needed for proper combustion and safe unit operation.
- When the furnace is installed in an attic or other insulated space, keep insulation away from the furnace.

!WARNING

Product contains fiberglass wool.

Disturbing the insulation in this product during installation, maintenance, or repair will expose you to fiberglass wool. Breathing this may cause lung cancer. (Fiberglass wool is known to the State of California to cause cancer.)

Fiberglass wool may also cause respiratory, skin, and eye irritation.

To reduce exposure to this substance or for further information, consult material safety data sheets available from address shown below, or contact your supervisor.

**Lennox Industries Inc.
P.O. Box 799900
Dallas, TX 75379-9900**

Combustion, Dilution & Ventilation Air

In the past, there was no problem in bringing in sufficient outdoor air for combustion. Infiltration provided all the air that was needed. In today's homes, tight construction practices make it necessary to bring in air from outside for combustion. Take into account that exhaust fans, appliance vents, chimneys, and fireplaces force additional air that could be used for combustion out of the house. Unless outside air is brought into the house for combustion, negative pressure (outside pressure is greater than inside pressure) will build to the point that a downdraft can occur in the furnace vent pipe or chimney. As a result, combustion gases enter the living space creating a potentially dangerous situation.

In the absence of local codes concerning air for combustion and ventilation, use the guidelines and procedures in this section to install G50UH(X) furnaces to ensure efficient and safe operation. You must consider combustion air needs and requirements for exhaust vents and gas piping. A portion of this information has been reprinted with permission from the National Fuel Gas Code (ANSI-Z223.1). This reprinted material is not the complete and official position of the ANSI on the referenced subject, which is represented only by the standard in its entirety.

In Canada, refer to the standard CSA B149 installation codes.

!CAUTION

Do not install the furnace in a corrosive or contaminated atmosphere. Meet all combustion and ventilation air requirements, as well as all local codes.

!CAUTION

Insufficient combustion air can cause headaches, nausea, dizziness or asphyxiation. It will also cause excess water in the heat exchanger resulting in rusting and premature heat exchanger failure. Excessive exposure to contaminated combustion air will result in safety and performance related problems. Avoid exposure to the following substances in the combustion air supply:

**Permanent wave solutions
Chlorinated waxes and cleaners
Chlorine base swimming pool chemicals
Water softening chemicals
De-icing salts or chemicals
Carbon tetrachloride
Halogen type refrigerants
Cleaning solvents (such as perchloroethylene)
Printing inks, paint removers, varnishes, etc.
Hydrochloric acid
Cements and glues
Antistatic fabric softeners for clothes dryers
Masonry acid washing materials**

All gas-fired appliances require air for the combustion process. If sufficient combustion air is not available, the furnace or other appliances will operate inefficiently and unsafely. Enough air must be provided to meet the needs of all fuel-burning appliances and appliances such as exhaust fans which force air out of the house. When fireplaces, exhaust fans, or clothes dryers are used at the same time as the furnace, much more air is necessary to ensure proper combustion and to prevent a downdraft. Insufficient air causes incomplete combustion which can result in carbon monoxide.

In addition to providing combustion air, fresh outdoor air dilutes contaminants in the indoor air. These contaminants may include bleaches, adhesives, detergents, solvents and other contaminants which can corrode furnace components.

The requirements for providing air for combustion and ventilation depend largely on whether the furnace is installed in an unconfined or a confined space.

Unconfined Space

An unconfined space is an area such as a basement or large equipment room with a volume greater than 50 cubic feet (1.42 m³) per 1,000 Btu (.29 kW) per hour of the combined input rating of all appliances installed in that space. This space also includes adjacent rooms which are not separated by a door. Though an area may appear to be unconfined, it might be necessary to bring in outdoor air for combustion if the structure does not provide enough air by

infiltration. If the furnace is located in a building of tight construction with weather stripping and caulking around the windows and doors, follow the procedures in the air from outside section.

Confined Space

A confined space is an area with a volume less than 50 cubic feet (1.42 m³) per 1,000 Btu (.29 kW) per hour of the combined input rating of all appliances installed in that space. This definition includes furnace closets or small equipment rooms.

When the furnace is installed so that supply ducts carry air circulated by the furnace to areas outside the space containing the furnace, the return air must be handled by ducts which are sealed to the furnace casing and which terminate outside the space containing the furnace. This is especially important when the furnace is mounted on a platform in a confined space such as a closet or small equipment room. Even a small leak around the base of the unit at the platform or at the return air duct connection can cause a potentially dangerous negative pressure condition. Air for combustion and ventilation can be brought into the confined space either from inside the building or from outside.

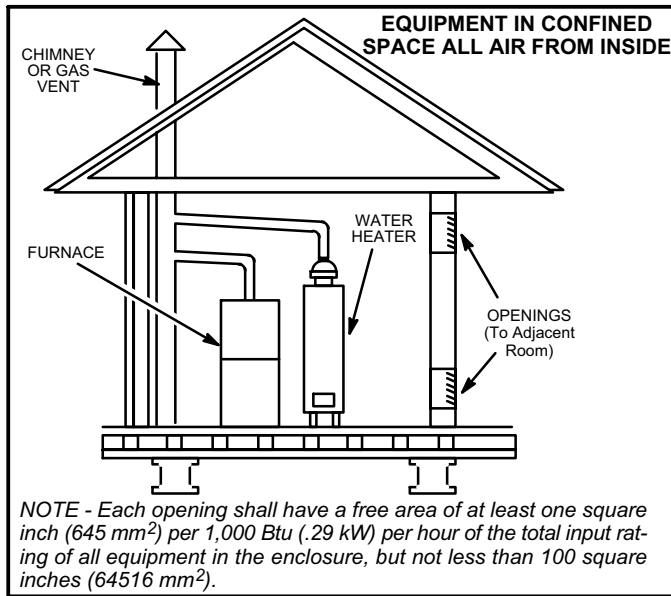

FIGURE 2

Air from Inside

If the confined space that houses the furnace adjoins a space categorized as unconfined, air can be brought in by providing two permanent openings between the two spaces. Each opening must have a minimum free area of 1 square inch (645 mm²) per 1,000 Btu (.29 kW) per hour of total input rating of all gas-fired equipment in the confined space. Each opening must be at least 100 square inches (64516 mm²). One opening shall be within 12 inches (305 mm) of the top of the enclosure and one opening within 12 inches (305 mm) of the bottom. See figure 2.

Air from Outside

If air from outside is brought in for combustion and ventilation, the confined space must have two permanent openings. One opening shall be within 12 inches (305 mm) of the top of the enclosure and one opening within 12 inches (305 mm) of the bottom. These openings must communicate directly or by ducts with the outdoors or spaces (crawl or attic) that freely communicate with the outdoors or indirectly through vertical ducts. Each opening shall have a minimum free area of 1 square inch (645 mm²) per 4,000 Btu (1.17 kW) per hour of total input rating of all equipment in the enclosure. See figures 3 and 4. When communicating with the outdoors through horizontal ducts, each opening shall have a minimum free area of 1 square inch (645 mm²) per 2,000 Btu (.56 kW) per total input rating of all equipment in the enclosure. See figure 5.

When ducts are used, they shall be of the same cross-sectional area as the free area of the openings to which they connect. The minimum dimension of rectangular air ducts shall be no less than 3 inches (75 mm). In calculating free area, the blocking effect of louvers, grilles, or screens must be considered. If the design and free area of protective covering is not known for calculating the size opening required, it may be assumed that wood louvers will have 20 to 25 percent free area and metal louvers and grilles will have 60 to 75 percent free area. Louvers and grilles must be fixed in the open position or interlocked with the equipment so that they are opened automatically during equipment operation.

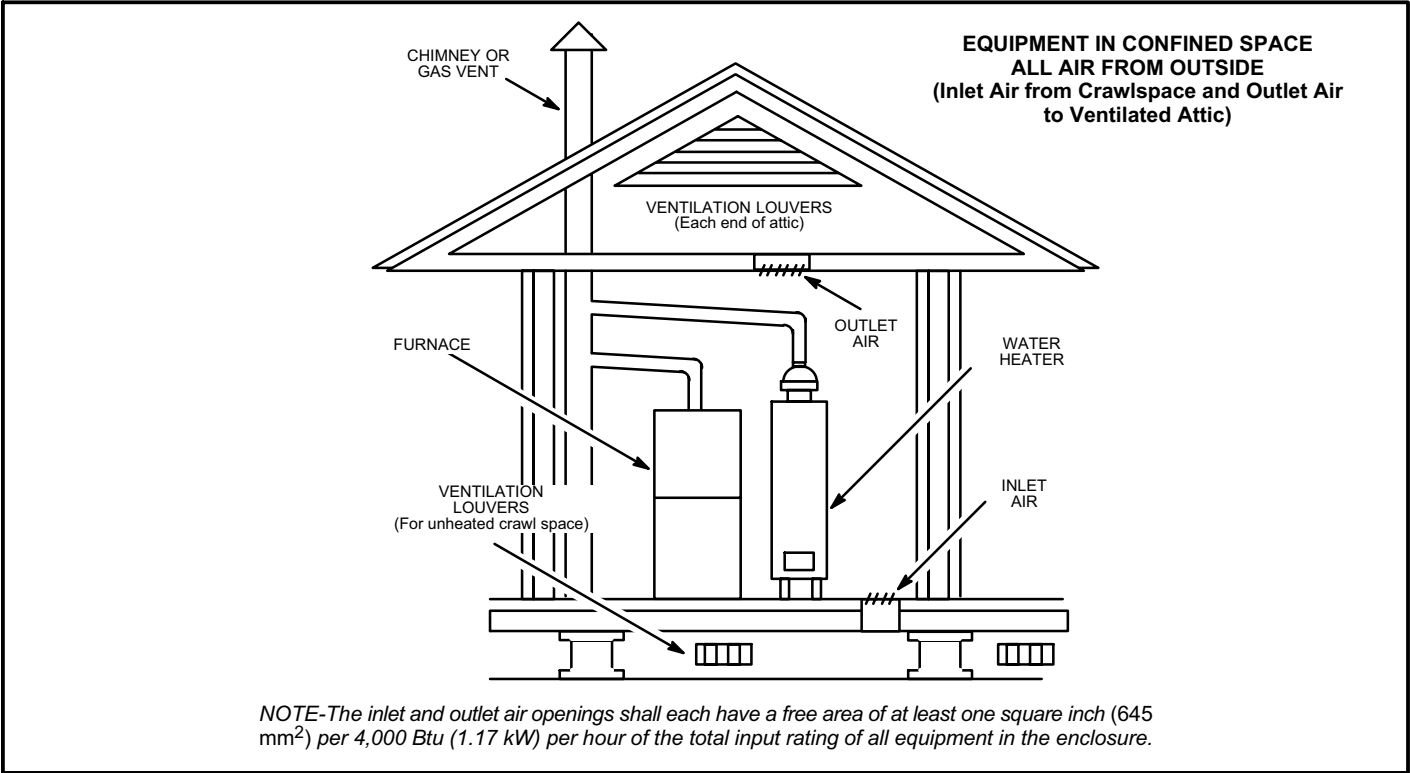

FIGURE 3

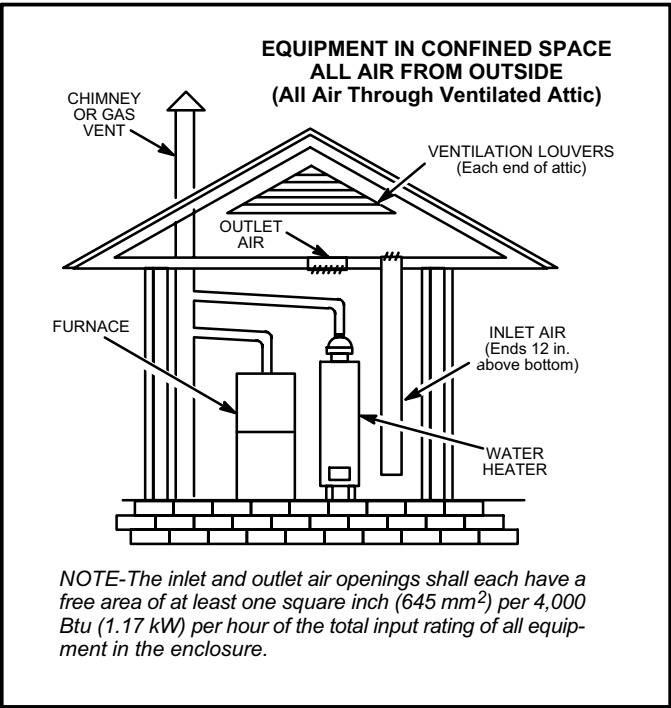

FIGURE 4

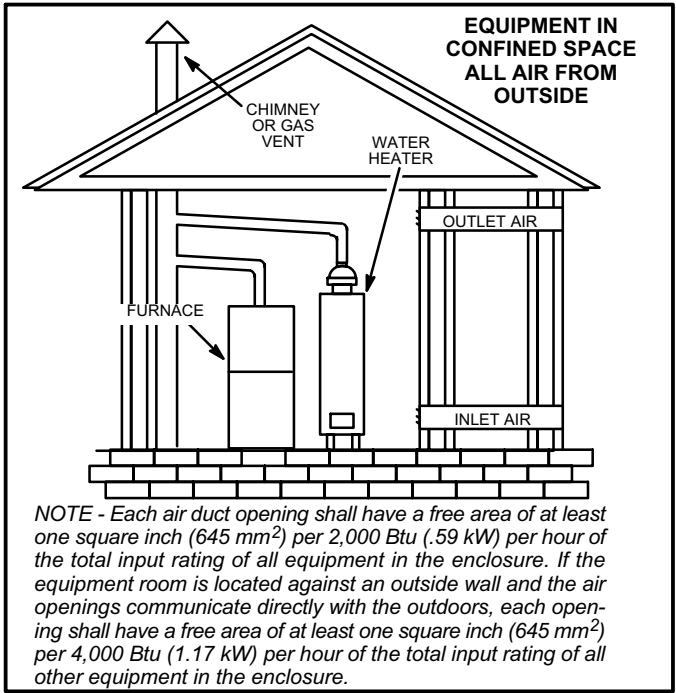

FIGURE 5

Setting Equipment

⚠ WARNING

Do not install the furnace on its front or its back. Do not connect the return air ducts to the back of the furnace. Doing so will adversely affect the operation of the safety control devices, which could result in personal injury or death.

The G50UH(X) gas furnace can be installed as shipped in either the upflow position or the horizontal position, with right-hand or left-hand air discharge.

Select a location that allows for the required clearances that are listed on the unit nameplate. Also consider gas supply connections, electrical supply, vent connection, and installation and service clearances [24 inches (610 mm) at unit front]. *The unit must be level.*

*NOTE - 1/3 hp blower motors are equipped with four flexible mounting legs. 1/2 hp blower motors are equipped with three flexible legs and one rigid leg. The rigid leg is equipped with a shipping bolt and a flat white plastic washer (rather than the rubber mounting grommet used with a flexible mounting leg). **The bolt and washer must be removed before the furnace is placed into operation.** After the bolt and washer have been removed, the rigid leg will not touch the blower housing.*

Upflow Applications

Allow for clearances to combustible materials as indicated on the unit nameplate. Minimum clearances for closet or alcove installations are shown in figure 6.

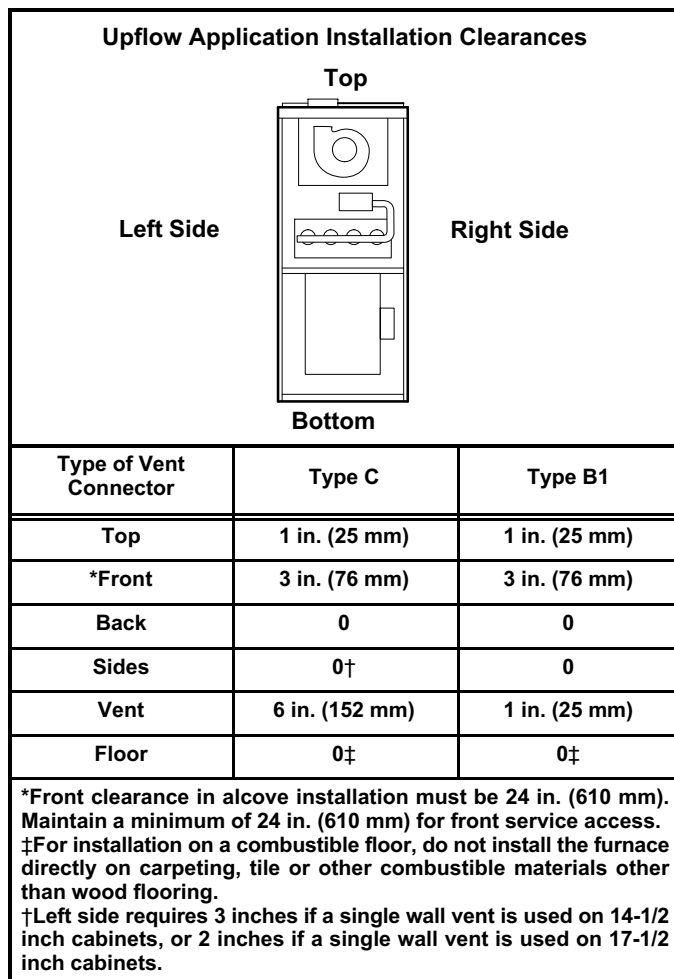

FIGURE 6

Return Air -- Upflow Applications

Return air can be brought in through the bottom or either side of the furnace installed in an upflow application. If the furnace is installed on a platform with bottom return, make an airtight seal between the bottom of the furnace and the platform to ensure that the furnace operates properly and safely. The furnace is equipped with a removable bottom panel to facilitate installation.

Markings are provided on both sides of the furnace cabinet for installations that require side return air. Cut the furnace cabinet at the maximum dimensions shown on page 2.

NOTE - When air volumes over 1800 cfm (850 L/s) are required with 60C or 60D models in an upflow application, the following return air options are available:

- 1 - Return air from single side with transition which will accommodate 20 x 25 x 1 in. (508 x 635 x 25 mm) cleanable air filter. (Required to maintain proper air velocity.) See figure 7.
- 2 - Return air from single side with optional RAB Return Air Base. See figure 8.
- 3 - Return air from bottom.
- 4 - Return air from both sides.

5 - Return air from bottom and one side.
Refer to Engineering Handbook for additional information.

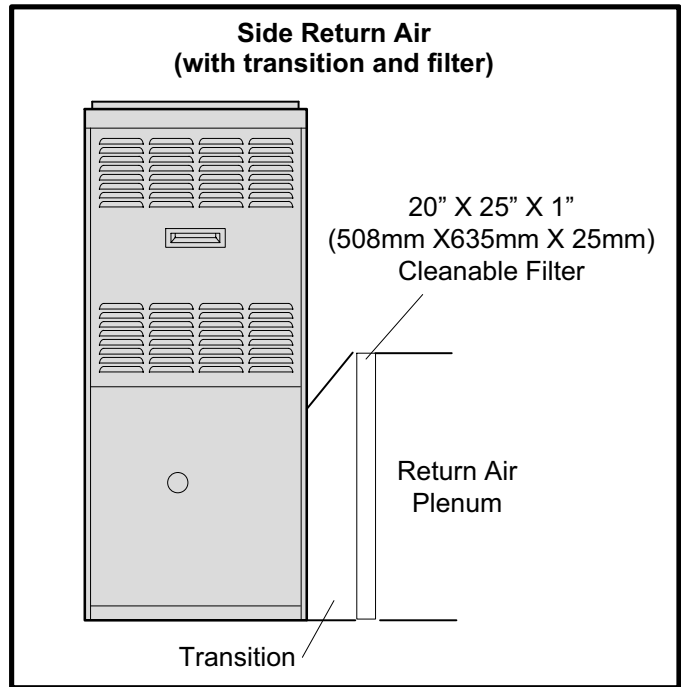

FIGURE 7

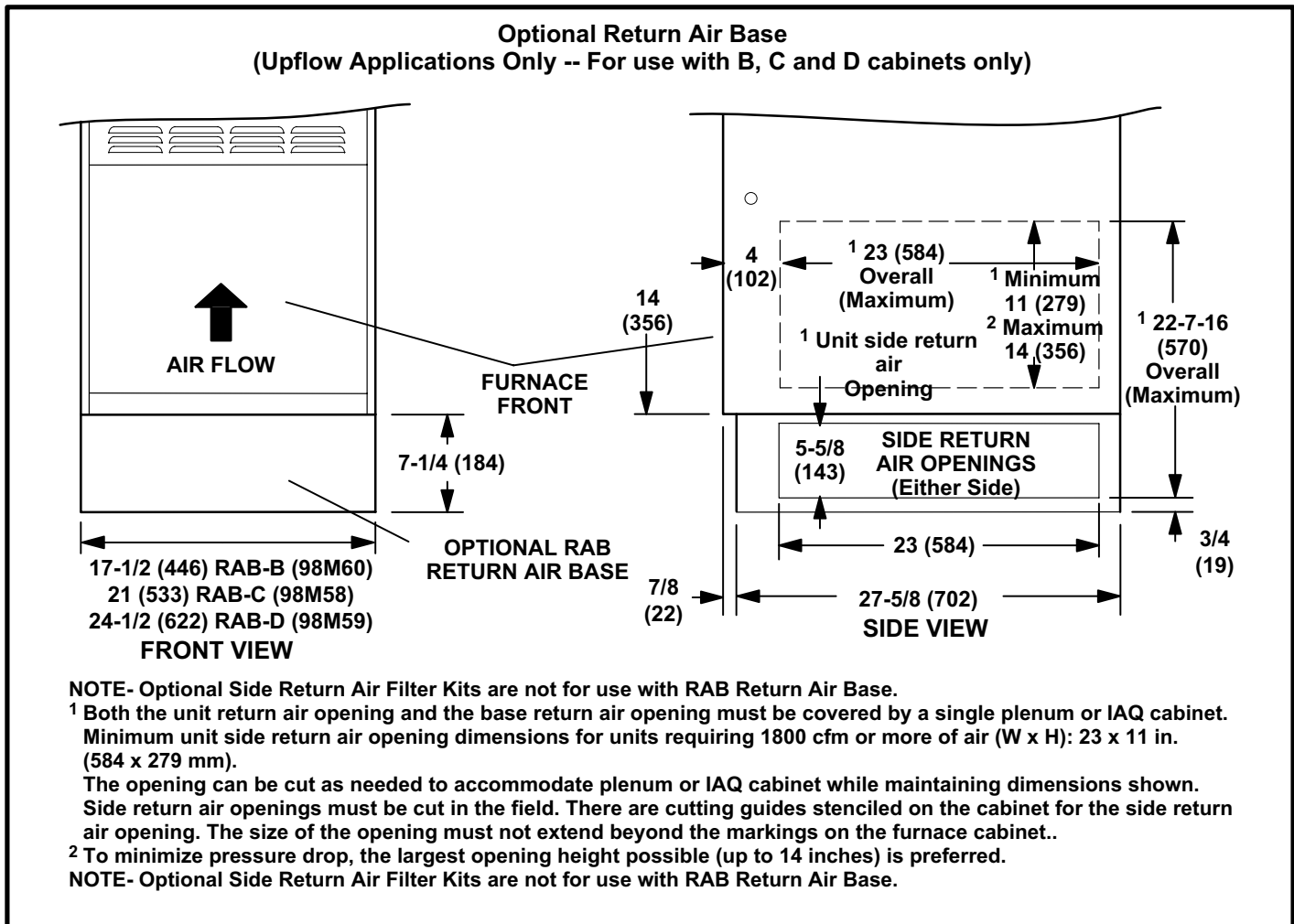

FIGURE 8

NOTE- Optional Side Return Air Filter Kits are not for use with RAB Return Air Base.

¹ Both the unit return air opening and the base return air opening must be covered by a single plenum or IAQ cabinet. Minimum unit side return air opening dimensions for units requiring 1800 cfm or more of air (W x H): 23 x 11 in. (584 x 279 mm).

The opening can be cut as needed to accommodate plenum or IAQ cabinet while maintaining dimensions shown.

Side return air openings must be cut in the field. There are cutting guides stenciled on the cabinet for the side return air opening. The size of the opening must not extend beyond the markings on the furnace cabinet..

² To minimize pressure drop, the largest opening height possible (up to 14 inches) is preferred.

NOTE- Optional Side Return Air Filter Kits are not for use with RAB Return Air Base.

Removing the Bottom Panel

Remove the two screws that secure the bottom cap to the furnace. Pivot the bottom cap down to release the bottom panel. Once the bottom panel has been removed, reinstall the bottom cap. See figure 9.

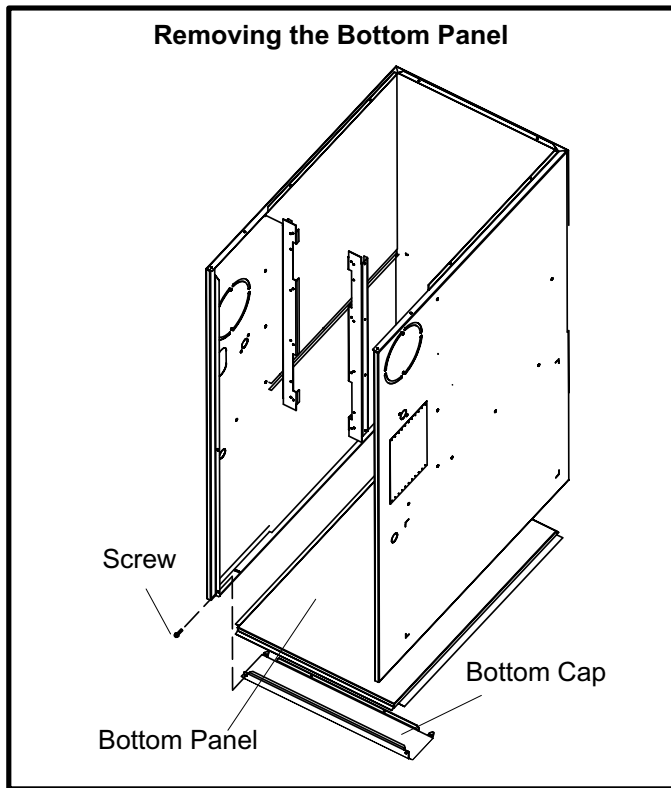

FIGURE 9

Leveling an Upflow Unit

When the side return air inlets are used in an upflow application, it may be necessary to install leveling bolts on the bottom of the furnace. Use field-supplied corrosion-resistant 5/16 inch machine bolts (4) and nuts (8). See figure 10.

NOTE - The maximum length of the bolt is 1-1/2 inches.

- 1 - Lie the furnace on its back and drill a 5/16 inch diameter hole in each corner of the furnace's bottom. See figure 10 for the correct location of the holes. Drill through the bottom panel and the bottom flange of the cabinet.
- 2 - Install one bolt and two nuts into each hole. Screw the first nut onto a bolt and then insert the bolt into a hole. A flat washer may be added between the nut and the bottom of the unit.
- 3 - Screw another nut onto the bolt on the inside of the furnace base. A flat washer may be added between the nut and the bottom of the unit.
- 4 - Adjust the outside nut to the appropriate height and tighten the inside nut to secure the arrangement.

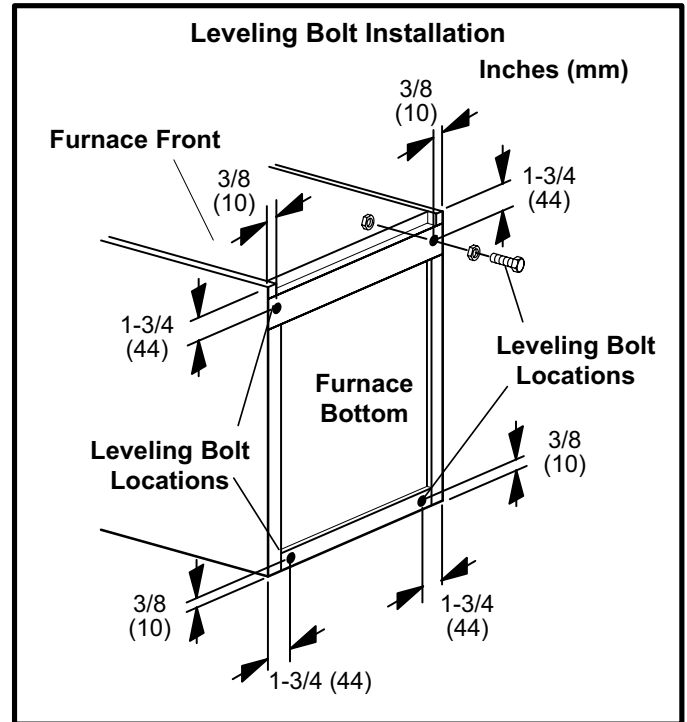

FIGURE 10

Horizontal Applications

The G50UH(X) furnace can be installed in horizontal applications.

Allow for clearances to combustible materials as indicated on the unit nameplate. Minimum clearances for closet or alcove installations are shown in figure 11.

Horizontal Application Installation Clearances		
	Top	
	Left End	Right End
	Bottom	
Vent Connector Type	Type C	Type B1
Top	0	0
*Front	3 in. (76 mm)	3 in. (76 mm)
Back	0	0
Ends	2 in. (51 mm)	2 in. (51 mm)
Vent	6 in. (152 mm)	1 in. (25 mm)
Floor	0‡	0‡

*Front clearance in alcove installation must be 24 in. (610 mm). Maintain a minimum of 24 in. (610 mm) for front service access.
 ‡For installations on a combustible floor, do not install the furnace directly on carpeting, tile or other combustible materials other than wood flooring.

FIGURE 11

This furnace may be installed in either an attic or a crawlspace. Either suspend the furnace from roof rafters or floor joists, as shown in figure 12, or install the furnace on a platform, as shown in figure 13. The unit must be supported at both ends and beneath the blower deck to prevent sagging.

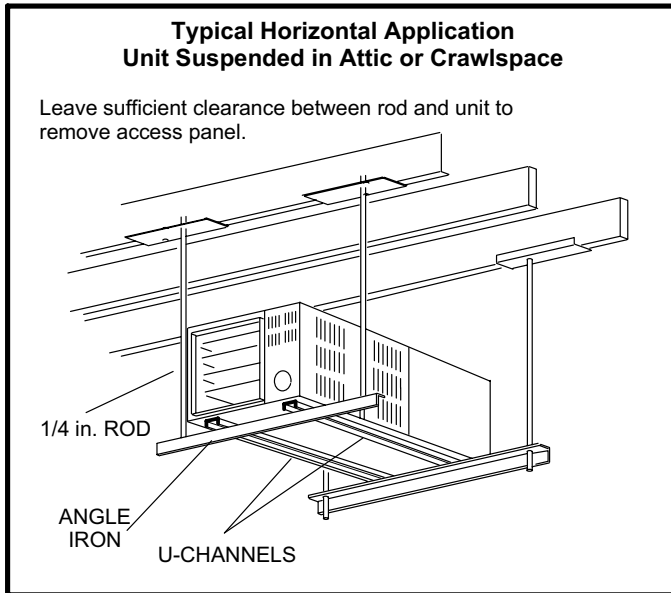

FIGURE 12

NOTE - Heavy-gauge perforated sheet metal straps (plumbers' straps) may be used to suspend the unit from roof rafters or ceiling joists. When straps are used to suspend the unit in this way, support must be provided for both the ends and the middle of the furnace to prevent sagging. The straps must not interfere with the plenum or exhaust piping installation. Securing screws should be 1/2 inch from the top edge and 1-1/2 inch from the side edge in all cases. **Cooling coils and supply and return air plenums must be supported separately.**

NOTE - When the furnace is installed on a platform in a crawlspace, it must be elevated enough to avoid water damage and to allow the evaporator coil to drain.

Return Air -- Horizontal Applications

Return air can be brought in through the end of a furnace installed in a horizontal application. The furnace is equipped with a removable bottom panel to facilitate installation. See figure 9.

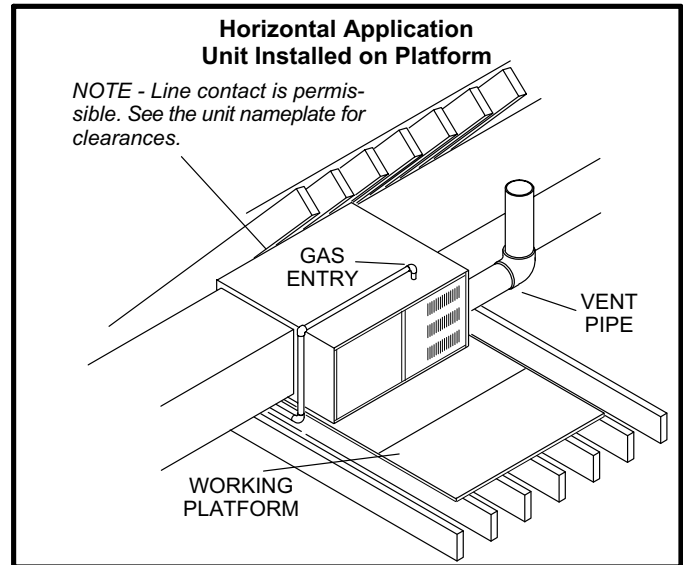

FIGURE 13

⚠ WARNING

Improper installation of the furnace can result in personal injury or death. Combustion and flue products must never be allowed to enter the return air system or the living space. Use screws and joint tape to seal the return air system to the furnace.

In platform installations with bottom return air, the furnace should be sealed airtight to the return air plenum. A door must never be used as a portion of the return air duct system. The base must provide a stable support and an airtight seal to the furnace. Allow absolutely no sagging, cracks, gaps, etc.

The return and supply air duct systems must never be connected to or from other heating devices such as a fireplace or stove, etc. Fire, explosion, carbon monoxide poisoning, personal injury and/or property damage could result.

⚠ WARNING

The blower access panel must be securely in place when the blower and burners are operating. Gas fumes, which could contain carbon monoxide, can be drawn into living space resulting in personal injury or death.

Filters

This unit is not equipped with a filter or rack. A field-provided high-velocity filter is required for the unit to operate properly. Table 1 lists recommended filter sizes.

A filter must be in place any time the unit is operating.

TABLE 1

Furnace Cabinet Size	Filter Size	
	Side Return	Bottom Return
14-1/2"	16 X 25 X 1 (1)	14 X 25 X 1 (1)
17-1/2"	16 X 25 X 1 (1)	16 X 25 X 1 (1)
21"	16 X 25 X 1 (1)	20 X 25 X 1 (1)
24-1/2"	16 X 25 X 1 (2)	24 X 25 X 1 (1)

Duct System

Use industry-approved standards to size and install the supply and return air duct system. This will result in a quiet and low-static system that has uniform air distribution.

NOTE - Do not operate the furnace with an external static pressure that exceeds 0.5 inches w.c. Higher external static pressures may cause erratic limit operation.

Supply Air Plenum

If the furnace is installed without a cooling coil, a removable access panel must be installed in the supply air duct. The access panel should be large enough to permit inspection (either by smoke or reflected light) of the heat exchanger for leaks after the furnace is installed. The furnace access panel must always be in place when the furnace is operating and it must not allow leaks into the supply air duct system.

Return Air Plenum

NOTE - Return air must not be drawn from a room where this furnace, or any other gas-fueled appliance (i.e., water heater), or carbon monoxide-producing device (i.e., wood fireplace) is installed.

When return air is drawn from a room, a negative pressure is created in the room. If a gas appliance is operating in a room with negative pressure, the flue products can be pulled back down the vent pipe and into the room. This reverse flow of the flue gas may result in incomplete combustion and the formation of carbon monoxide gas. This toxic gas might then be distributed throughout the house by the furnace duct system.

In upflow applications, the return air can be brought in through the bottom or either side of the furnace. If a furnace with bottom return air is installed on a platform, make an airtight seal between the bottom of the furnace and the platform to ensure that the unit operates properly and safely. Use fiberglass sealing strips, caulking, or equivalent sealing method between the plenum and the furnace cabinet to ensure a tight seal. If a filter is installed, size the return air duct to fit the filter frame.

Venting

A 4-inch diameter flue transition is factory-installed on the combustion air inducer outlet of all models. **Modifying or removing the flue transition will cause the unit to operate unsafely and will void the unit certification.** The vent connector does not require insulation.

The combustion air inducer may be rotated clockwise or counterclockwise by 90° to allow for top or side vent discharge in all applications. When the unit is installed, the flue transition must be in the 9 o'clock, 12 o'clock or 3 o'clock position. **The unit will not vent properly with the flue transition pointed down in the 6 o'clock position.** Remove the four mounting screws, rotate the assembly (including the gasket), then reinstall the mounting screws. See figure 14. Use the provided wire tie to bundle the pressure switch wires with the inducer motor power leads. **Route the wires away from moving parts and the heat of the inducer motor to prevent damage to the wires.**

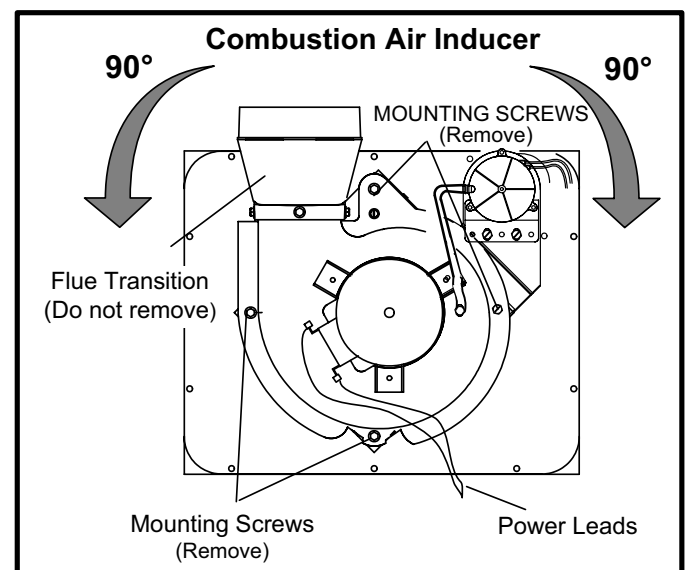

FIGURE 14

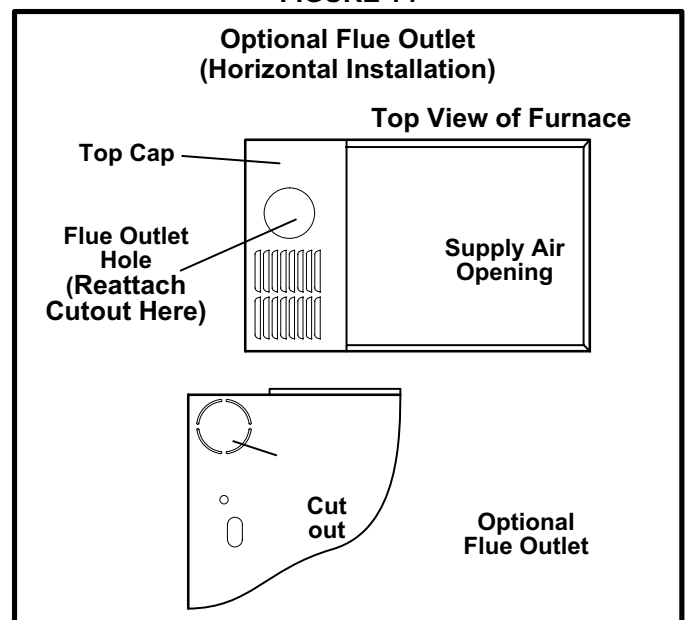

FIGURE 15

Use sheet metal shears to remove the cut out from the side of the cabinet. Use the two provided sheet metal screws to install the cut out on the top cap to cover the original flue outlet opening. See figure 15.

The G50UH(X) series units are classified as fan-assisted Category I furnaces when vertically vented according to the latest edition of National Fuel Gas Code (NFPA 54 / ANSI Z223.1) in the USA and the current standards of CSA B149 Natural Gas and Propane Installation Codes in Canada. A fan-assisted Category I furnace is an appliance equipped with an integral mechanical means to either draw or force combustion products through the combustion chamber and/or heat exchanger.

NOTE - Use these instructions as a guide. They do not supersede local codes. This furnace must be vented according to all local codes these installation instructions, and the provided venting tables in these instructions

The venting tables in this manual were extracted from the National Fuel Gas Code (NFPA 54 / ANSI Z223.1) and are provided as a guide for proper vent installation. Proper application, termination, construction and location of vents must conform to local codes having jurisdiction. In the absence of local codes, the NFGC serves as the defining document.

Refer to the tables and the venting information contained in these instructions to properly size and install the venting system.

⚠ IMPORTANT

Once the venting system is installed, attach the "Disconnected Vent" warning sticker to a visible area of the plenum near the vent pipe. The warning sticker is provided in the bag assembly.

⚠ WARNING

Asphyxiation hazard. The exhaust vent for this furnace must be securely connected to the furnace flue transition at all times.

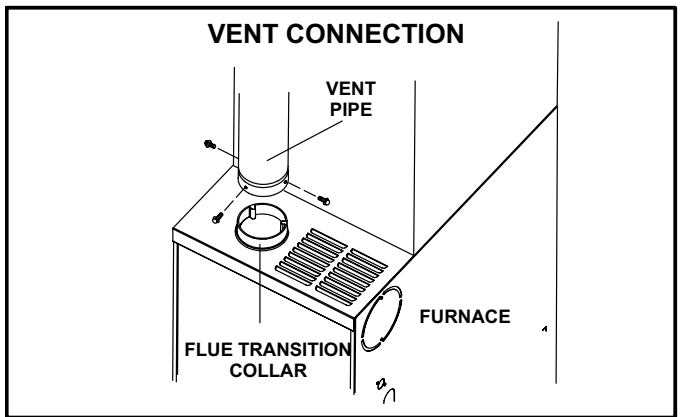

FIGURE 16

Use self-drilling sheet metal screws or a mechanical fastener to firmly secure the vent pipe to the round collar of the

flue transition. If self-drilling screws are used to attach the vent pipe, it is recommended that three be used. Drive one self-drilling screw through the front and one through each side of the vent pipe and collar. See figure 16.

Install the first vent connector elbow at a minimum of six inches (152 mm) from the furnace vent outlet.

Venting Using a Masonry Chimney

The following additional requirements apply when a lined masonry chimney is used to vent this furnace.

Masonry chimneys used to vent Category I central furnaces must be either tile-lined or lined with a listed metal lining system or dedicated gas vent. Unlined masonry chimneys are prohibited. See figures 17 and 18 for common venting.

A chimney with one or more sides exposed to the outside of the structure is considered to be an exterior chimney.

An exterior masonry chimney that is not tile-lined must be lined with B1 vent or a listed insulated flexible metal vent. An exterior tile-lined chimney that is sealed and capped may be lined with a listed uninsulated flexible metal vent.

If the existing chimney will not accommodate a B1 vent or an insulated flexible vent pipe liner, either the chimney must be rebuilt to accommodate one of these liners or an alternate approved venting method must be found.

Insulation for the flexible vent pipe must be an encapsulated fiberglass sleeve recommended by the flexible vent pipe manufacturer. See figure 17.

G50UH units installed in upflow applications may be vented into a tile-lined masonry chimney without using a listed metal liner, provided that the optional masonry chimney vent adapter kit (18M79) is used. Instructions provided with the kit must be followed exactly.

DO NOT insulate the space between the liner and the chimney wall with puffed mica or any other loose granular insulating material

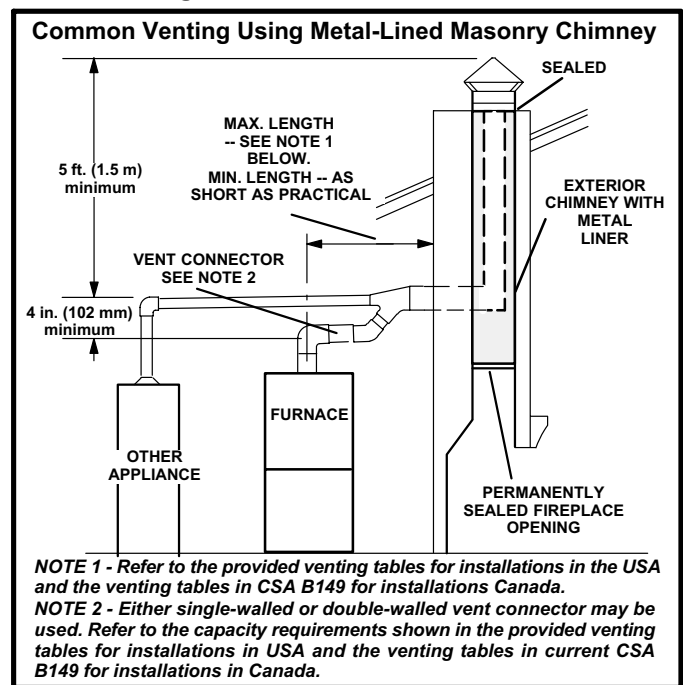
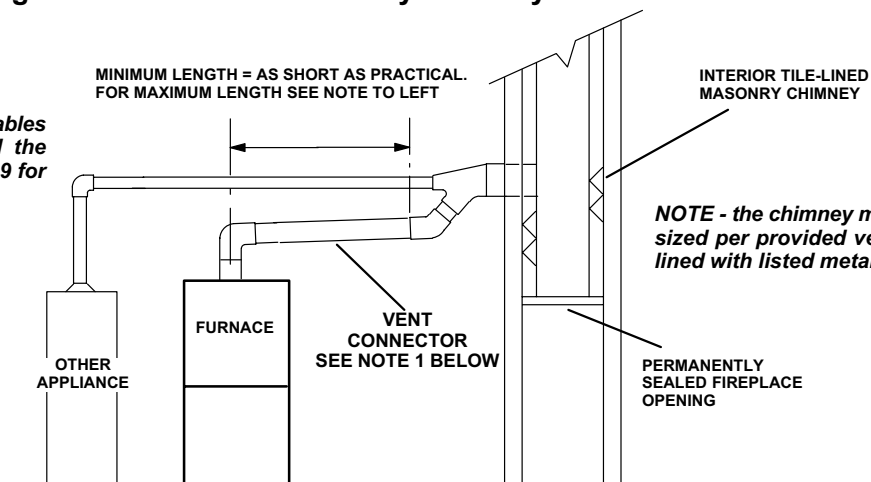

FIGURE 17

Common Venting Using Tile-Lined Interior Masonry Chimney and Combined Vent Connector

NOTE- Refer to provided venting tables for installations in the USA and the venting tables in current CSA B149 for installations in Canada.



NOTE - Either single-walled or double-walled vent connector may be used. Refer to the capacity requirements as shown in the provided venting tables for installations in USA and the venting tables in current CSA B149 for installations in Canada.

FIGURE 18

▲ IMPORTANT

SINGLE appliance venting of a fan-assisted furnace into a tile-lined masonry chimney (interior or outside wall) is **PROHIBITED**. The chimney must first be lined with either type B1 vent or an insulated single wall flexible vent lining system which has been sized according to the provided venting tables and the vent pipe manufacturer's instructions.

A fan-assisted furnace may be commonly vented into an existing lined masonry chimney if the following conditions are met:

- The chimney is currently serving at least one draffhood equipped appliance
- The vent connectors and chimney are sized according to the provided venting tables for the USA, and the appropriate venting tables in the standards of CSA B149 Natural Gas and Propane Installation Codes in Canada.

If type B1 double-wall vent is used inside a chimney, no other appliance can be vented into the chimney. The outer wall of type B1 vent pipe must not be exposed to flue products.

A type B1 vent or masonry chimney liner shall terminate above the roof surface with a listed cap or a listed roof assembly according to the terms of their respective listings and the vent manufacturer's instructions.

When inspection reveals that an existing chimney is not safe for the intended purpose, it shall be rebuilt to conform to nationally recognized standards, lined or relined with suitable materials, or replaced with a gas vent or chimney suitable for venting G50UH(X) series units. The chimney passageway must be checked periodically to ensure that it is clear and free of obstructions.

Do not install a manual damper, barometric draft regulator, or flue restrictor between the furnace and the chimney.

Never connect a Category I appliance to a chimney that is servicing a solid-fuel appliance. If a fireplace chimney flue is used to vent this appliance, the fireplace opening must be permanently sealed.

A type B or listed chimney lining system that passes through an unused masonry chimney flue is not considered to be exposed to the outdoors.

General Venting Requirements

Vent all G50UH(X) furnaces according to these instructions:

- 1 - Vent diameter recommendations and maximum allowable piping runs are found in the provided venting tables for the USA, and the appropriate venting tables in the standards of CSA B149 Natural Gas and Propane Installation Codes for Canada.
- 2 - In no case should the vent or vent connector diameter be less than the diameter specified in the provided venting tables for the USA, and the appropriate venting tables in the standards of CSA B149 Natural Gas and Propane Installation Codes for Canada.
- 3 - *Single appliance vents* - If the vertical vent or tile-lined chimney has a larger diameter or flow area than the vent connector, use the **vertical vent diameter** to determine the **minimum vent capacity** and the **vent connector diameter** to determine the **maximum vent capacity**. The flow area of the vertical vent, however, shall not exceed 7 times the flow area of the listed appliance categorized vent area, draffhood outlet area or flue collar area unless designed according to approved engineering methods.
- 4 - *Multiple appliance vents* - The flow area of the largest section of vertical vent or chimney shall not exceed 7 times the smallest listed appliance categorized vent area, draffhood outlet area or flue collar area unless designed according to approved engineering methods.

- 5 - The entire length of single wall metal vent connector shall be readily accessible for inspection, cleaning, and replacement.
- 6 - Single appliance venting configurations with zero lateral lengths (tables 3 and 4) are assumed to have no elbows in the vent system. For all other vent configurations, the vent system is assumed to have two 90° elbows. For each additional 90° elbow or equivalent (for example two 45° elbows equal one 90° elbow) beyond two, the maximum capacity listed in the venting table should be reduced by 10% (0.90 x maximum listed capacity).
- 7 - The common venting tables (5, 6, 7, and 8) were generated using a maximum horizontal vent connector length of 1-1/2 feet (.46 m) for each inch (25 mm) of connector diameter as follows:

TABLE 2

Connector Diameter inches (mm)	Maximum Horizontal Connector Length feet (m)
3 (76)	4-1/2 (1.37)
4 (102)	6 (1.83)
5 (127)	7-1/2 (2.29)
6 (152)	9 (2.74)
7 (178)	10-1/2 (3.20)

- 8 - If the common vertical vent is offset, the maximum common vent capacity listed in the common venting tables should be reduced by 20%, the equivalent of two 90° elbows (0.80 x maximum common vent capacity). The horizontal length of the offset shall not exceed 1-1/2 feet (.46 m) for each inch (25 mm) of common vent diameter.
- 9 - The vent pipe should be as short as possible with the least number of elbows and angles required to complete the job. Route the vent connector to the vent using the shortest possible route.
- 10 - A vent connector shall be supported without any dips or sags and shall slope a minimum of 1/4 inch (6.4 mm) per linear foot (305 mm) of connector, back toward the appliance.
- 11 - Vent connectors shall be firmly attached to the furnace flue collar by self-drilling screws or other approved

means, except vent connectors of listed type B vent material which shall be assembled according to the manufacturer's instructions. Joints between sections of single wall connector piping shall be fastened by screws or other approved means.

- 12 - When the vent connector used for Category I appliances must be located in or pass through a crawlspace or other areas which may be cold, that portion of the vent connector shall be constructed of listed double-wall type B vent material or material having equivalent insulation qualities.
- 13 - All venting pipe passing through floors, walls, and ceilings must be installed with the listed clearance to combustible materials and be fire stopped according to local codes. In absence of local codes, refer to NFPA (Z223.1).
- 14 - No portion of the venting system can extend into, or pass through any circulation air duct or plenum.
- 15 - Vent connectors serving Category I appliances shall not be connected to any portion of mechanical draft systems operating under positive pressure such as Category III or IV venting systems.
- 16 - If vent connectors are combined prior to entering the common vent, the maximum common vent capacity listed in the common venting tables must be reduced by 10%, the equivalent of one 90° elbow (0.90 x maximum common vent capacity).
- 17 - The common vent diameter must always be at least as large as the largest vent connector diameter.
- 18 - In no case, shall the vent connector be sized more than two consecutive table size diameters over the size of the draft hood outlet or flue collar outlet.
- 19 - Do not install a manual damper, barometric draft regulator or flue restrictor between the furnace and the chimney.
- 20 - When connecting this appliance to an existing dedicated or common venting system, you must inspect the venting system's general condition and look for signs of corrosion. The existing vent pipe size must conform to these instructions and the provided venting tables for the USA, and the appropriate venting tables in the standards of CSA B149 Natural Gas and Propane Installation Codes for Canada. If the existing venting system does not meet these requirements, it must be resized.

TABLE 3
Capacity of Type B Double-Wall Vents with Type B Double-Wall Connectors
Serving a Single Category I Appliance

Height H (feet)	Lateral L (feet)	Vent and Connector Diameter - D (inches)							
		3 Inch		4 Inch		5 Inch		6 Inch	
		Appliance Input Rating in Thousands of Btu Per Hour							
		MIN	MAX	MIN	MAX	MIN	MAX	MIN	MAX
6	0	0	78	0	152	0	251	0	375
	2	13	51	18	97	27	157	32	232
	4	21	49	30	94	39	153	50	227
	6	25	46	36	91	47	149	59	223
8	0	0	84	0	165	0	276	0	415
	2	12	57	16	109	25	178	28	263
	5	23	53	32	103	42	171	53	255
	8	28	49	39	98	51	164	64	247
10	0	0	88	0	175	0	295	0	447
	2	12	61	17	118	23	194	26	289
	5	23	57	32	113	41	187	52	280
	10	30	51	41	104	54	176	67	267
15	0	0	94	0	191	0	327	0	502
	2	11	69	15	136	20	226	22	339
	5	22	65	30	130	39	219	49	330
	10	29	59	40	121	51	206	64	315
	15	35	53	48	112	61	195	76	301
20	0	0	97	0	202	0	349	0	540
	2	10	75	14	149	18	250	20	377
	5	21	71	29	143	38	242	47	367
	10	28	64	38	133	50	229	62	351
	15	34	58	46	124	59	217	73	337
	20	48	52	55	116	69	206	84	322
30	0	0	100	0	213	0	374	0	587
	2	9	81	13	166	14	283	18	432
	5	21	77	28	160	36	275	45	421
	10	27	70	37	150	48	262	59	405
	15	33	64	44	141	57	249	70	389
	20	56	58	53	132	66	237	80	374
	30	NR	NR	73	113	88	214	104	346

NOTE - Single appliance venting configurations with zero lateral lengths are assumed to have no elbows in the vent system. For all other vent configurations, the vent system is assumed to have two 90° elbows. For each additional 90° elbow or equivalent (for example two 45° elbows equal one 90° elbow) beyond two, the maximum capacity listed in the venting table should be reduced by 10 percent (0.90 x maximum listed capacity).

TABLE 4
Capacity of Type B Double-Wall Vents with Single-Wall Metal Connectors
Serving a Single Category I Appliance

Height H (feet)	Lateral L (feet)	Vent and Connector Diameter - D (inches)							
		3 Inch		4 Inch		5 Inch		6 Inch	
		Appliance Input Rating in Thousands of Btu Per Hour							
		MIN	MAX	MIN	MAX	MIN	MAX	MIN	MAX
6	0	38	77	59	151	85	249	126	373
	2	39	51	60	96	85	156	123	231
	4	NR	NR	74	92	102	152	146	225
	6	NR	NR	83	89	114	147	163	220
8	0	37	83	58	164	83	273	123	412
	2	39	56	59	108	83	176	121	261
	5	NR	NR	77	102	107	168	151	252
	8	NR	NR	90	95	122	161	175	243
10	0	37	87	57	174	82	293	120	444
	2	39	61	59	117	82	193	119	287
	5	52	56	76	111	105	185	148	277
	10	NR	NR	97	100	132	171	188	261
15	0	36	93	56	190	80	325	116	499
	2	38	69	57	136	80	225	115	337
	5	51	63	75	128	102	216	144	326
	10	NR	NR	95	116	128	201	182	308
	15	NR	NR	NR	NR	158	186	220	290
20	0	35	96	54	200	78	346	114	537
	2	37	74	56	148	78	248	113	375
	5	50	68	73	140	100	239	141	363
	10	NR	NR	93	129	125	223	177	344
	15	NR	NR	NR	NR	155	208	216	325
	20	NR	NR	NR	NR	186	192	254	306
30	0	34	99	53	211	76	372	110	584
	2	37	80	55	164	76	281	109	429
	5	49	74	72	157	98	271	136	417
	10	NR	NR	91	144	122	255	171	397
	15	NR	NR	115	131	151	239	208	377
	20	NR	NR	NR	NR	181	223	246	357
	30	NR	NR	NR	NR	NR	NR	NR	NR

NOTE - Single appliance venting configurations with zero lateral lengths are assumed to have no elbows in the vent system. For all other vent configurations, the vent system is assumed to have two 90° elbows. For each additional 90° elbow or equivalent (for example two 45° elbows equal one 90° elbow) beyond two, the maximum capacity listed in the venting table should be reduced by 10 percent (0.90 x maximum listed capacity).

TABLE 5
Vent Connector Capacity
Type B Double-Wall Vents with Type B Double-Wall Connectors
Serving Two or More Category I Appliances

Vent Height H (feet)	Connector Rise R (feet)	Vent and Connector Diameter - D (inches)							
		3 Inch		4 Inch		5 Inch		6 Inch	
		Appliance Input Rating in Thousands of Btu Per Hour							
		MIN	MAX	MIN	MAX	MIN	MAX	MIN	MAX
6	1	22	37	35	66	46	106	58	164
	2	23	41	37	75	48	121	60	183
	3	24	44	38	81	49	132	62	199
8	1	22	40	35	72	49	114	64	176
	2	23	44	36	80	51	128	66	195
	3	24	47	37	87	53	139	67	210
10	1	22	43	34	78	49	123	65	189
	2	23	47	36	86	51	136	67	206
	3	24	50	37	92	52	146	69	220
15	1	21	50	33	89	47	142	64	220
	2	22	53	35	96	49	153	66	235
	3	24	55	36	102	51	163	68	248
20	1	21	54	33	99	46	157	62	246
	2	22	57	34	105	48	167	64	259
	3	23	60	35	110	50	176	66	271
30	1	20	62	31	113	45	181	60	288
	2	21	64	33	118	47	190	62	299
	3	22	66	34	123	48	198	64	309

TABLE 6
Common Vent Capacity
Type B Double-Wall Vents with Type B Double-Wall Connectors
Serving Two or More Category I Appliances

Vent Height H (feet)	Common Vent Diameter - D (inches)							
	4 Inch		5 Inch		6 Inch		7 Inch	
	Appliance Input Rating in Thousands of Btu Per Hour							
	FAN + FAN	FAN + NAT	FAN + FAN	FAN + NAT	FAN + FAN	FAN + NAT	FAN + FAN	FAN + NAT
6	92	81	140	116	204	161	309	248
8	101	90	155	129	224	178	339	275
10	110	97	169	141	243	194	367	299
15	125	112	195	164	283	228	427	352
20	136	123	215	183	314	255	475	394
30	152	138	244	210	361	297	547	459

TABLE 7
Vent Connector Capacity
Type B Double-Wall Vents with Single-Wall Metal Connectors
Serving Two or More Category I Appliances

Vent Height H (feet)	Connector Rise R (feet)	Vent and Connector Diameter - D (inches)							
		3 Inch		4 Inch		5 Inch		6 Inch	
		Appliance Input Rating in Thousands of Btu Per Hour							
		MIN	MAX	MIN	MAX	MIN	MAX	MIN	MAX
6	1	NR	NR	NR	NR	NR	NR	NR	NR
	2	NR	NR	NR	NR	NR	NR	168	182
	3	NR	NR	NR	NR	121	131	174	198
15	1	NR	NR	79	87	116	138	177	214
	2	NR	NR	83	94	121	150	185	230
	3	NR	NR	87	100	127	160	193	243
30	1	47	60	77	110	113	175	169	278
	2	50	62	81	115	117	185	177	290
	3	54	64	85	119	122	193	185	300

TABLE 8
Common Vent Capacity
Type B Double-Wall Vents with Single-Wall Metal Connectors
Serving Two or More Category I Appliances

Vent Height H (feet)	Common Vent Diameter - D (inches)							
	4 Inch		5 Inch		6 Inch		7 Inch	
	Appliance Input Rating in Thousands of Btu Per Hour							
	FAN + FAN	FAN + NAT	FAN + FAN	FAN + NAT	FAN + FAN	FAN + NAT	FAN + FAN	FAN + NAT
6	89	78	136	113	200	158	304	244
8	98	87	151	126	218	173	331	269
10	106	94	163	137	237	189	357	292
15	121	108	189	159	275	221	416	343
20	131	118	208	177	305	247	463	383
30	145	132	236	202	350	286	533	446

Removal of the Furnace from Common Vent

In the event that an existing furnace is removed from a venting system commonly run with separate gas appliances, the venting system is likely to be too large to properly vent the remaining attached appliances.

Conduct the following test while each appliance is operating and the other appliances (which are not operating) remain connected to the common venting system. If the venting system has been installed improperly, you **must** correct the system as indicated in the general venting requirements section.

- 1 - Seal any unused openings in the common venting system.
- 2 - Inspect the venting system for proper size and horizontal pitch. Determine that there is no blockage, restriction, leakage, corrosion, or other deficiencies which could cause an unsafe condition.
- 3 - Close all building doors and windows and all doors between the space in which the appliances remaining connected to the common venting system are located

and other spaces of the building. Turn on clothes dryers and any appliances not connected to the common venting system. Turn on any exhaust fans, such as range hoods and bathroom exhausts, so they will operate at maximum speed. Do not operate a summer exhaust fan. Close fireplace dampers.

- 4 - Follow the lighting instructions. Turn on the appliance that is being inspected. Adjust the thermostat so that the appliance operates continuously.
- 5 - After the main burner has operated for 5 minutes, test for leaks of flue gases at the draft hood relief opening. Use the flame of a match or candle, or smoke from a cigarette, cigar, or pipe.
- 6 - After determining that each appliance connected to the common venting system is venting properly, (step 3) return all doors, windows, exhaust fans, fireplace dampers, and any other gas-burning appliances to their previous mode of operation.
- 7 - If a venting problem is found during any of the preceding tests, the common venting system must be modified to correct the problem.

Resize the common venting system to the minimum vent pipe size determined by using the appropriate tables in appendix G. (These are in the current standards of the National Fuel Gas Code ANSI Z223.1 in the USA, and the appropriate Category 1 Natural Gas and Propane appliances venting sizing tables in the current standards of the CSA B149 Natural Gas and Propane Installation Codes in Canada.)

Gas Piping

⚠ CAUTION
 If a flexible gas connector is required or allowed by the authority that has jurisdiction, black iron pipe shall be installed at the gas valve and extend outside the furnace cabinet.

Gas Supply

- 1 - This unit is shipped standard for left or right side installation of gas piping (or top entry in horizontal applications). Connect the gas supply to the piping assembly.
- 2 - When connecting the gas supply piping, consider factors such as length of run, number of fittings, and furnace rating to avoid excessive pressure drop. Table 9 lists recommended pipe sizes for typical applications.

- 3 - The gas piping must not run in or through air ducts, clothes chutes, gas vents or chimneys, dumb waiters, or elevator shafts.
- 4 - The piping should be sloped 1/4 inch (6.4 mm) per 15 feet (4.57 m) upward toward the meter from the furnace. The piping must be supported at proper intervals [every 8 to 10 feet (2.44 to 3.01 m)] with suitable hangers or straps. Install a drip leg inside vertical pipe runs to the unit.
- 5 - In some localities, codes may require the installation of a manual main shut-off valve and union (furnished by the installer) external to the unit. The union must be of the ground joint type.

⚠ IMPORTANT
 Compounds used on threaded joints of gas piping must be resistant to the actions of liquified petroleum gases.

NOTE - Install a 1/8 inch NPT plugged tap in the field piping upstream of the gas supply connection to the unit. The tap must be accessible for test gauge connection. See figure 19.

NOTE - If emergency shutoff is necessary, shut off the main manual gas valve and disconnect main power to the furnace. The installer should properly label these devices.

TABLE 9
Gas Pipe Capacity - ft³/hr (m³/hr)

Nominal Iron Pipe Size inches (mm)	Internal Diameter inches (mm)	Length of Pipe - feet (m)									
		10 (3.048)	20 (6.096)	30 (9.144)	40 (12.192)	50 (15.240)	60 (18.288)	70 (21.336)	80 (24.384)	90 (27.432)	100 (30.480)
3/8 (9.53)	.493 (12.522)	95 (2.69)	65 (1.84)	52 (1.47)	45 (1.27)	40 (1.13)	36 (1.02)	33 (.73)	31 (.88)	29 (.82)	27 (.76)
1/2 (12.7)	.622 (17.799)	175 (4.96)	120 (3.40)	97 (2.75)	82 (2.32)	73 (2.07)	66 (1.87)	61 (1.73)	57 (1.61)	53 (1.50)	50 (1.42)
3/4 (19.05)	.824 (20.930)	360 (10.19)	250 (7.08)	200 (5.66)	170 (4.81)	151 (4.28)	138 (3.91)	125 (3.54)	118 (3.34)	110 (3.11)	103 (2.92)
1 (25.4)	1.049 (26.645)	680 (919.25)	465 (13.17)	375 (10.62)	320 (9.06)	285 (8.07)	260 (7.36)	240 (6.80)	220 (6.23)	205 (5.80)	195 (5.52)
1-1/4 (31.75)	1.380 (35.052)	1400 (39.64)	950 (26.90)	770 (21.80)	660 (18.69)	580 (16.42)	530 (15.01)	490 (13.87)	460 (13.03)	430 (12.18)	400 (11.33)
1-1/2 (38.1)	1.610 (40.894)	2100 (59.46)	1460 (41.34)	1180 (33.41)	990 (28.03)	900 (25.48)	810 (22.94)	750 (21.24)	690 (19.54)	650 (18.41)	620 (17.56)
2 (50.8)	2.067 (52.502)	3950 (111.85)	2750 (77.87)	2200 (62.30)	1900 (53.80)	1680 (47.57)	1520 (43.04)	1400 (39.64)	1300 (36.81)	1220 (34.55)	1150 (32.56)
2-1/2 (63.5)	2.469 (67.713)	6300 (178.39)	4350 (123.17)	3520 (99.67)	3000 (84.95)	2650 (75.04)	2400 (67.96)	2250 (63.71)	2050 (58.05)	1950 (55.22)	1850 (52.38)
3 (76.2)	3.068 (77.927)	11000 (311.48)	7700 (218.03)	6250 (176.98)	5300 (150.07)	4750 (134.50)	4300 (121.76)	3900 (110.43)	3700 (104.77)	3450 (97.69)	3250 (92.03)

NOTE - Capacity given in cubic feet (m³) of gas per hour and based on 0.60 specific gravity gas.

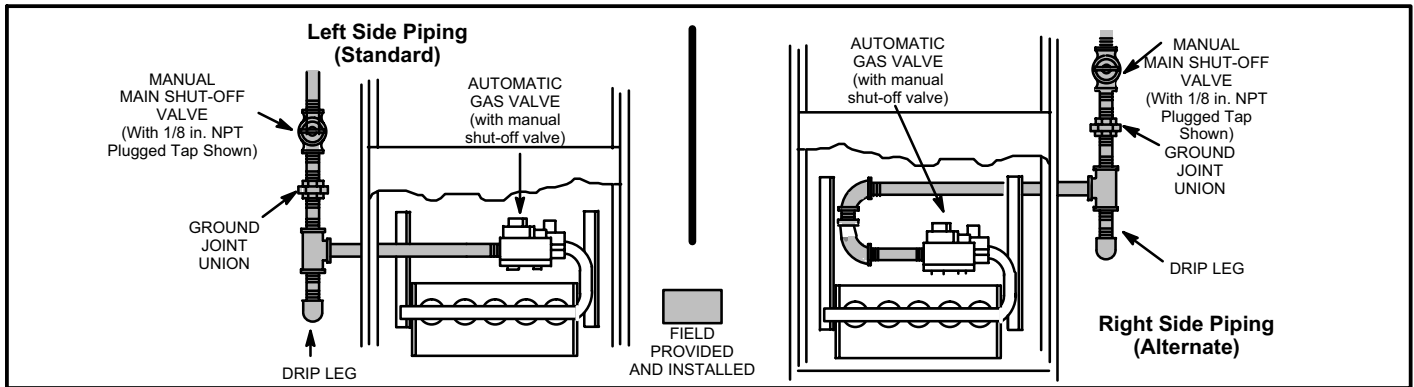

FIGURE 19

Leak Check

After gas piping is completed, carefully check all piping connections (factory- and field-installed) for gas leaks. Use a leak detecting solution or other preferred means.

NOTE - If emergency shutoff is necessary, shut off the main manual gas valve and disconnect the main power to the furnace. The installer should properly label these devices.

⚠ CAUTION

Some soaps used for leak detection are corrosive to certain metals. Carefully rinse piping thoroughly after leak test has been completed. Do not use matches, candles, flame or other sources of ignition to check for gas leaks.

The furnace must be isolated from the gas supply system by closing its individual manual shut-off valve during any pressure testing of the gas supply system at pressures less than or equal to 1/2 psig (3.48 kPa, 14 inches w.c.).

⚠ IMPORTANT

When testing pressure of gas lines, gas valve must be disconnected and isolated. See figure 20. Gas valves can be damaged if subjected to pressures greater than 1/2 psig (3.48 kPa, 14 inches w.c.).

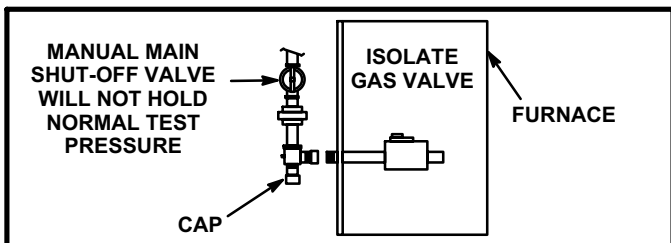

FIGURE 20

Electrical

**ELECTROSTATIC DISCHARGE (ESD)
Precautions and Procedures**

⚠ CAUTION

Electrostatic discharge can affect electronic components. Take precautions during furnace installation and service to protect the furnace's electronic controls. Precautions will help to avoid control exposure to electrostatic discharge by putting the furnace, the control and the technician at the same electrostatic potential. Neutralize electrostatic charge by touching hand and all tools on an unpainted unit surface, such as the gas valve or blower deck, before performing any service procedure.

The unit is equipped with a field make-up box. The make-up box may be moved to the right side of the furnace to facilitate installation. If the make-up box is moved to the right side, the excess wire must be pulled into the blower compartment. Secure the excess wire to the existing harness to protect it from damage.

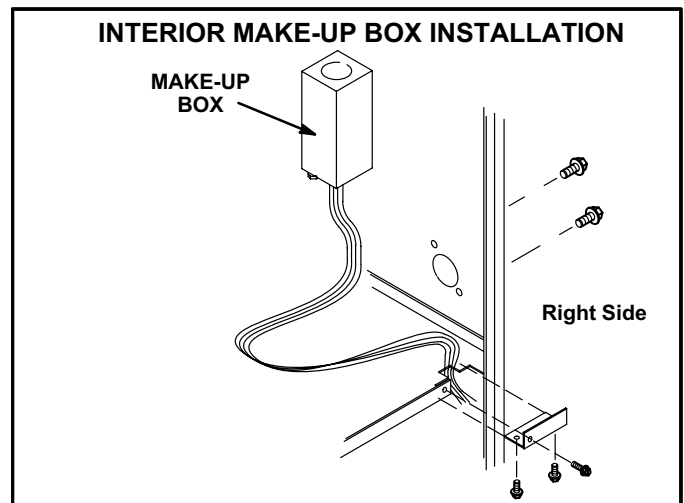

FIGURE 21

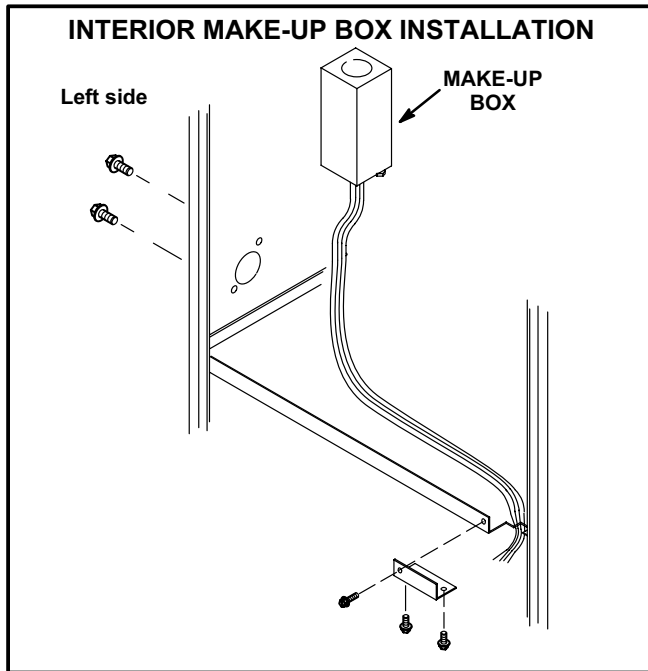

FIGURE 22

Refer to figure 24 for field wiring and figure 26 for schematic wiring diagram and troubleshooting.

- 1 - Select circuit protection and wire size according to the unit nameplate. The power supply wiring must meet Class I restrictions.
- 2 - Holes are on both sides of the furnace cabinet to facilitate wiring.
- 3 - Install a separate disconnect switch (protected by either fuse or circuit breaker) near the furnace so that power can be turned off for servicing.
- 4 - Before connecting the thermostat or the power wiring, check to make sure the wires will be long enough for servicing at a later date. Remove the blower access panel to check the length of the wire.
- 5 - Complete the wiring connections to the equipment. Use the provided unit wiring diagram and the field wiring diagram shown in figure 24. Use 18-gauge wire or larger that is suitable for Class II rating for thermostat connections.
- 6 - Electrically ground the unit according to local codes or, in the absence of local codes, according to the current National Electric Code (ANSI/NFPA No. 70) for the USA and current Canadian Electric Code part 1 (CSA standard C22.1) for Canada. A green ground wire is provided in the field make-up box.

NOTE - The G50UH(X) furnace contains electronic components that are polarity sensitive. Make sure that the furnace is wired correctly and is properly grounded.

- 7 - One line voltage "EAC" terminal is provided on the furnace control board. Any electronic air cleaner rated up to one amp can be connected to this terminal with the neutral leg of the circuit being connected to any of the "NEUTRAL" terminals. See figure 25 for control board configuration. This terminal is energized when the blower is operating.
- 8 - One line voltage "HUM" terminal is provided on the furnace control board. A humidifier rated up to one amp can be connected to this terminal with the neutral leg of the circuit being connected to any of the "NEUTRAL" terminals. See figure 25 for control board configuration. This terminal is energized in the heating mode whenever the combustion air inducer is operating.
- 9 - One 24 volt terminal "24V HUM" is provided on the furnace control board. A humidifier rated up to 0.5 amp can be connected to this terminal with the common leg of the circuit being connected to the "C" terminal of the thermostat terminal block located on the control board.
- 10 - Install the room thermostat according to the instructions provided with the thermostat. See figure 23 for thermostat designations. If the furnace is being matched with a heat pump, refer to the FM21 installation instruction.

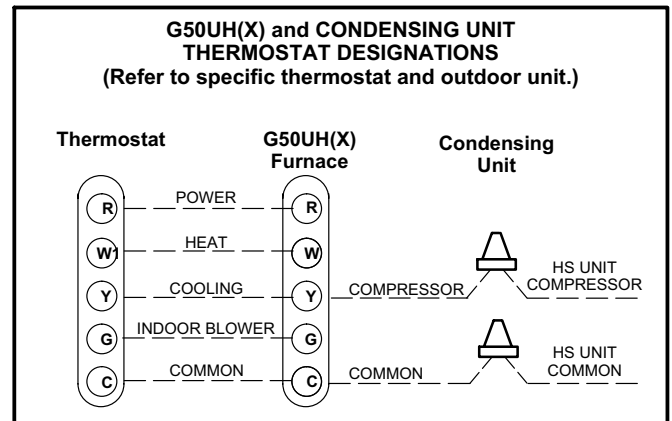

FIGURE 23

Indoor Blower Speeds

- 1 - When the thermostat is set to "FAN ON," the indoor blower will run continuously on the low speed when there is no cooling or heating demand.
- 2 - When the G50UH(X) is running in the heating mode, the indoor blower will run on the heating speed.
- 3 - When there is a cooling demand, the indoor blower will run on the cooling speed.

TYPICAL G50UH(X) FIELD WIRING DIAGRAM

WARNING-
ELECTRIC SHOCK HAZARD, CAN CAUSE INJURY OR DEATH. UNIT MUST BE GROUNDED IN ACCORDANCE WITH NATIONAL AND LOCAL CODES.

IF ANY WIRE IN THIS APPLIANCE IS REPLACED, IT MUST BE REPLACED WITH WIRE OF LIKE SIZE, RATING, INSULATION THICKNESS AND TERMINATION.

- ⚠ IMPORTANT- TO PREVENT MOTOR BURNOUT, NEVER CONNECT MORE THAN ONE MOTOR LEAD TO ANY ONE CONNECTION.
- ⚠ PARK TERMINALS ARE UNPOWERED TERMINALS. ALL UNUSED MOTOR LEADS MUST BE WIRED TO A PARK TERMINAL.
- ⚠ FOR CORRECT NUMBER OF SECONDARY LIMITS USED, SEE SECONDARY LIMIT SECTION OF BLOWER SPEED CHART.
- ⚠ FOR G50UH-36B-90 AND G50UH-48C-135 ONLY, DO NOT USE RED (LOW SPEED) MOTOR LEAD FOR HEATING SPEED. LEAVE ON PARK OR USE FOR CONTINUOUS AIR CIRCULATION (FAN).
- ⚠ FIELD SUPPLIED ACC. WIRE.
- ⚠ USE COPPER CONDUCTORS ONLY.
- ⚠ 24V HUM IS A 1/4" FEMALE QUICK CONNECT TERMINAL

--- FIELD INSTALLED CLASS II 24V
 _____ FIELD INSTALLED LINE VOLTAGE

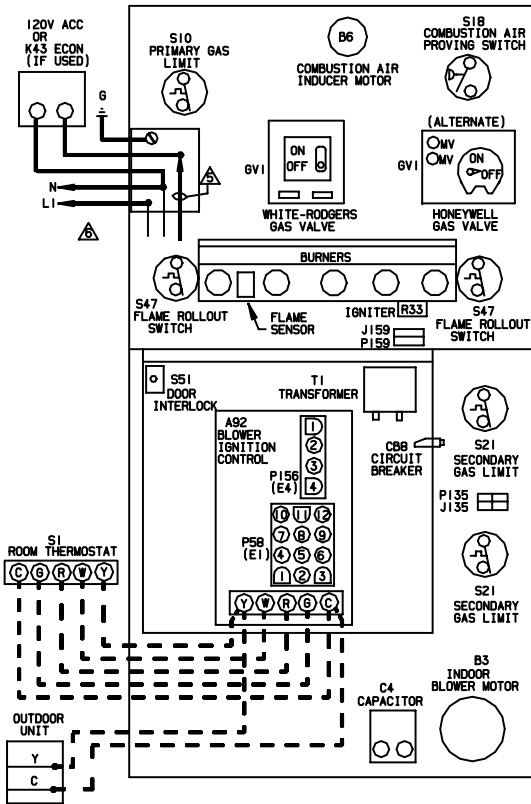
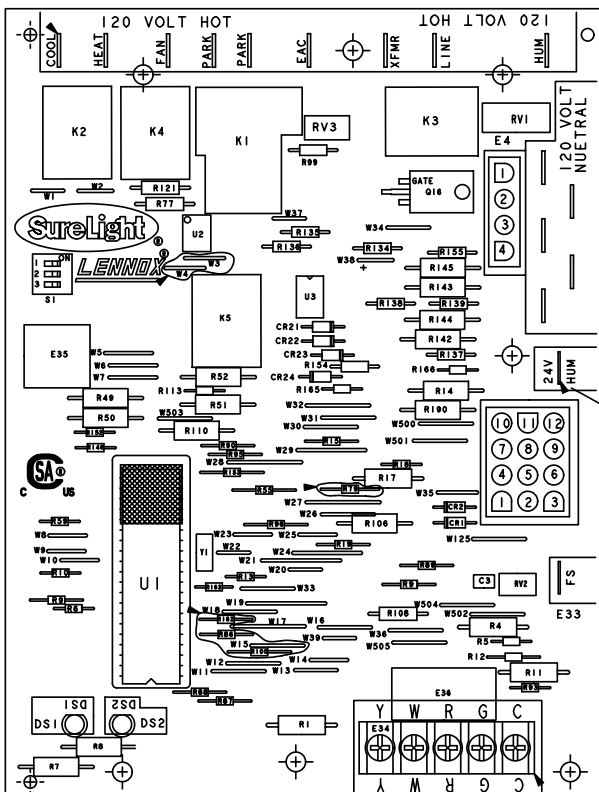

FIGURE 24

INTEGRATED CONTROL BOARD



TERMINAL DESIGNATIONS	
COOL	Blower - Cooling Speed (120VAC)
HEAT	Blower - Heating Speed (120VAC)
PARK	Unused Blower (Not energized)
FAN	Continuous Low Blower Speed
EAC	Accessory Terminal (120VAC)
XFMR	Transformer (120VAC)
LINE	Input (120VAC)
HUM	Heat Only Accessory (120VAC)
5 Terminals	120 Volt Neutral
FS	Flame Sensor
24V HUM	Heat Only Accessory (24VAC)

S1 DIP SWITCHES		
HEAT OFF DELAY		
1	2	SEC
OFF	OFF	60
OFF	ON	90 *
ON	OFF	120
ON	ON	180
COOL OFF DELAY		
3	/	SEC
OFF	/	2 *
ON	/	45

*Factory setting

FIGURE 25

G50UH(X) Schematic Wiring Diagram

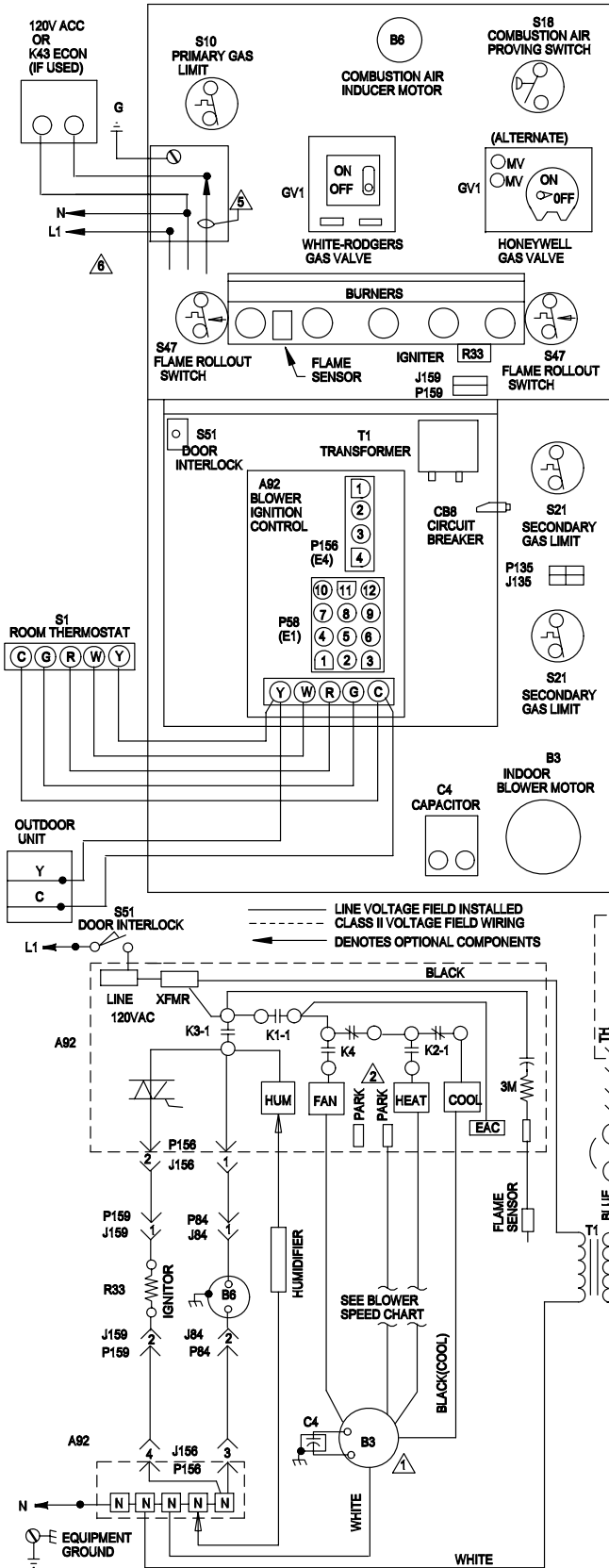

UNIT	FACTORY CONNECTED SPEED TAPS				MOTOR SPEEDS AVAIL.	SECONDARY LIMITS USED
	COOL	HEAT	FAN	PARK		
24A-045	YELLOW	RED	—	—	3	N/A
24A-070	YELLOW	RED	—	—	3	2
36A-070	YELLOW	RED	—	BROWN	4	2
36B-080	BROWN	RED	—	—	4	1(RIGHT)
36C-110	BROWN	RED	—	YELLOW	4	1(RIGHT)
48B-080	YELLOW	RED	—	BROWN	4	2
48C-110	BROWN	RED	—	YELLOW	4	1(RIGHT)
48C-135	BROWN	RED	—	YELLOW	4	2
60C-110	YELLOW	RED	—	BROWN	4	1(RIGHT)
60D-135	YELLOW	RED	—	BROWN	4	2
60D-155	YELLOW	RED	—	BROWN	4	2

BLOWER SPEED SELECTION

SPEED TAPS	BLACK	BROWN	YELLOW	RED
HI	—	—	—	—
LO	—	—	—	—
3	—	—	—	—
4	—	—	—	—

THERMOSTAT HEAT ANTICIPATION SETTINGS

.85 AMP	HONEYWELL VALVE
.60 AMP	WHITE-RODGERS VALVE

JACKPLUG CHART

J,P58	JACK/PLUG-BURNER CONTROL
J,P84	JACK/PLUG-COMB AIR INDUCER
J,P135	JACK/PLUG-SECONDARY LIMIT
J,P156	JACK/PLUG-INDUCER/IGNITER
J,P159	JACK/PLUG-IGNITION

WARNING- ELECTRIC SHOCK HAZARD CAN CAUSE INJURY OR DEATH. UNIT MUST BE GROUNDED IN ACCORDANCE WITH NATIONAL AND LOCAL CODES.

IF ANY WIRE IN THIS APPLIANCE IS REPLACED, IT MUST BE REPLACED WITH WIRE OF LIKE SIZE, RATING, INSULATION THICKNESS AND TERMINATION.

IMPORTANT- TO PREVENT MOTOR BURNOUT, NEVER CONNECT MORE THAN ONE MOTOR LEAD TO ANY ONE CONNECTION.

PARK TERMINALS ARE UNPOWERED TERMINALS. ALL UNUSED MOTOR LEADS MUST BE WIRED TO A PARK TERMINAL.

FOR CORRECT NUMBER OF SECONDARY LIMITS USED, SEE SECONDARY LIMIT SECTION OF BLOWER SPEED CHART.

FOR G50UH-36B-90 AND G50UH-48C-135 ONLY, DO NOT USE RED (LOW SPEED) MOTOR LEAD FOR HEATING SPEED. LEAVE ON PARK OR USE FOR CONTINUOUS AIR CIRCULATION (FAN).

FIELD SUPPLIED ACC. WIRE.

USE COPPER CONDUCTORS ONLY.

24V HUM IS A 1/4" FEMALE QUICK CONNECT TERMINAL.

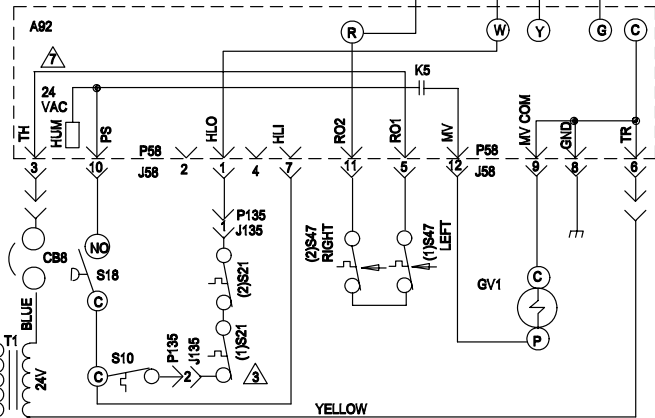
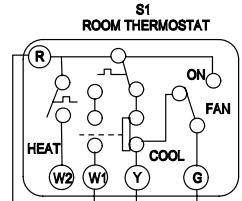

FIGURE 26

Unit Start-Up

FOR YOUR SAFETY READ BEFORE LIGHTING

⚠ WARNING

Do not use this furnace if any part has been underwater. Immediately call a licensed professional service technician to inspect the furnace and to replace any part of the control system and any gas control which has been under water.

⚠ WARNING

If overheating occurs or if gas supply fails to shut off, shut off the manual gas valve to the appliance before shutting off electrical supply.

⚠ CAUTION

Before attempting to perform any service or maintenance, turn the electrical power to unit OFF at disconnect switch.

BEFORE LIGHTING smell all around the appliance area for gas. Be sure to smell next to the floor because some gas is heavier than air and will settle on the floor.

The gas valve on the G50UH(X) unit may be equipped with either a gas control knob or gas control lever. Use only your hand to push the lever or to turn the gas control knob. Never use tools. If the knob will not turn or if the lever will not move by hand, do not try to repair it. Call a licensed professional service technician (or equivalent). Force or attempted repair may result in a fire or explosion.

Placing the furnace into operation:

G50UH(X) units are equipped with a SureLight® ignition system. Do not attempt to manually light burners on these furnaces. Each time the thermostat calls for heat, the burners will automatically light. The ignitor does not get hot when there is no call for heat on units with SureLight® ignition system.

⚠ WARNING

If you do not follow these instructions exactly, a fire or explosion may result causing property damage, personal injury or death.

Gas Valve Operation (Figures 27, 28 and 29)

- 1 - **STOP!** Read the safety information at the beginning of this section.
- 2 - Set the thermostat to the lowest setting.
- 3 - Turn off all electrical power to the unit.
- 4 - This furnace is equipped with an ignition device which automatically lights the burners. Do **not** try to light the burners by hand.

- 5 - Remove the upper access panel.
- 6 - *Honeywell VR8205 Gas Valve with ON/OFF Switch* - Move gas valve switch to **OFF**. See figure 27.
Honeywell VR8205 Gas Valve with Control Knob - Turn knob on gas valve clockwise ➡ to **OFF**. Do not force. See figure 28.
White Rodgers 36G Gas Valve - Move gas valve switch to **OFF**. See figure 29.
- 7 - Wait five minutes to clear out any gas. If you then smell gas, **STOP!** Immediately call your gas supplier from a neighbor's phone. Follow the gas supplier's instructions. If you do not smell gas go to next step.

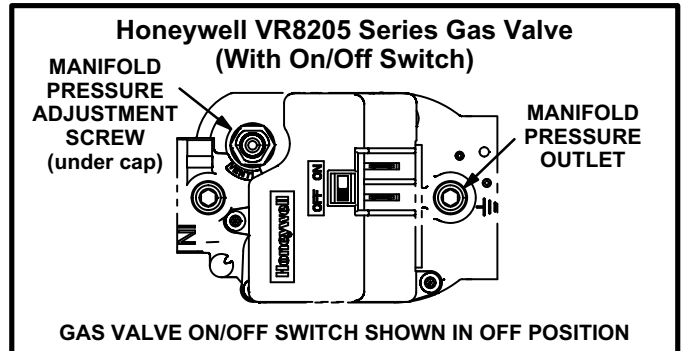

FIGURE 27

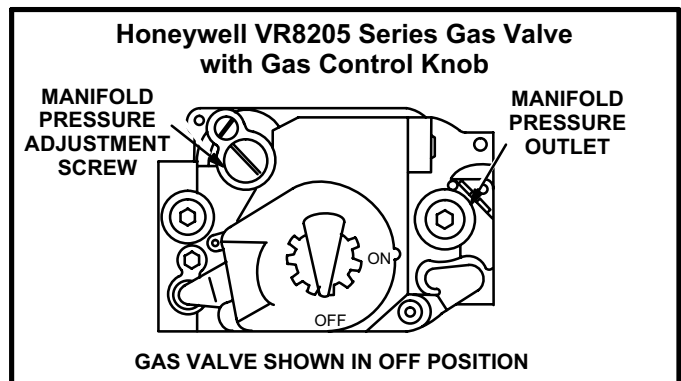

FIGURE 28

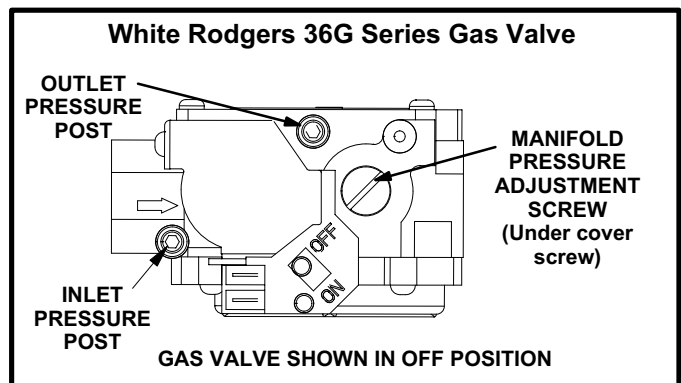



FIGURE 29

- 8 - *Honeywell VR8205 Gas Valve with ON/OFF Switch* - Move gas valve switch to **ON**. See figure 27.
Honeywell VR8205 Gas Valve with Control Knob - Turn knob on gas valve counterclockwise  to **ON**. Do not force. See figure 28.
White Rodgers 36G Gas Valve - Move gas valve switch to **ON**. See figure 29.

- 9 - Replace the upper access panel.
- 10- Turn on all electrical power to to the unit.
- 11- Set the thermostat to desired setting.

NOTE - When unit is initially started, steps 1 through 11 may need to be repeated to purge air from gas line.

- 12- If the appliance will not operate, follow the instructions "Turning Off Gas to Unit" and the gas supplier.

Turning Off Gas to Unit

- 1 - Set the thermostat to the lowest setting.
- 2 - Turn off all electrical power to the unit if service is to be performed.
- 3 - Remove the upper access panel.
- 4 - *Honeywell VR8205 Gas Valve with ON/OFF Switch* - Move gas valve switch to **OFF**. See figure 27.
Honeywell VR8205 Gas Valve with Control Knob - Turn knob on gas valve clockwise  to **OFF**. Do not force. See figure 28.
White Rodgers 36G Gas Valve - Move gas valve switch to **OFF**. See figure 29.
- 5 - Replace the upper access panel.

Heating Sequence Of Operation

- 1 - When thermostat calls for heat, combustion air inducer starts.
- 2 - Combustion air pressure switch proves combustion air inducer operation. Switch is factory set and requires no adjustment.
- 3 - After a 15 second prepurge, the hot surface ignitor energizes.
- 4 - After a 20 second ignitor warm-up period, the gas valve solenoid opens.
- 5 - Gas is ignited, flame sensor proves the flame, and the combustion process continues.
- 6 - If flame is not detected after first ignition trial, the ignition control will repeat steps 3 and 4 four more times before locking out the gas valve ("WATCHGUARD" flame failure mode). The ignition control will then automatically repeat steps 3, 4, 5, and 6 after 60 minutes.
- 7 - To interrupt the 60-minute "WATCHGUARD" period, move thermostat from "Heat" to "OFF" then back to "Heat". Heating sequence then restarts at step 1.

Gas Pressure Adjustment

Gas Flow (Approximate)

- 1 - Operate unit at least 15 minutes before checking gas flow. Determine the time in seconds for one revolutions of gas through the meter. A portable LP gas meter (17Y44) is available for LP applications.
- 2 - Compare the number of seconds and the gas meter size in table 10 to determine the gas flow rate. Multiply the gas flow rate by the heating value to determine the unit input rate. If manifold pressure is correct and the unit input rate is incorrect, check gas orifices for proper size and restriction.
- 3 - Remove temporary gas meter if installed.

NOTE - To obtain accurate reading, shut off all other gas appliances connected to meter.

TABLE 10

Gas Flow Rate (Ft. ³ /Hr.)		
Seconds for 1 Revolution	Gas Meter Size	
	1/2 cu ft Dial	1 cu ft Dial
10	180	360
12	150	300
14	129	257
16	113	225
18	100	200
20	90	180
22	82	164
24	75	150
26	69	138
28	64	129
30	60	120
32	56	113
34	53	106
36	50	100
38	47	95
40	45	90
42	43	86
44	41	82
46	39	78
48	38	75
50	36	72
52	35	69
54	33	67
56	32	64
58	31	62
60	30	60

Gas Pressure

- 1 - Check the gas line pressure with the unit firing at maximum rate. A minimum of 4.5 in. w.c. for natural gas or 11.0 in. w.c. for LP/propane gas should be maintained.

- 2 - After the line pressure has been checked and adjusted, check the manifold pressure. A natural gas to LP/propane gas changeover kit is required to convert the unit. Manifold pressure for all units fueled by natural gas at all altitudes is 3.5" w.c. Manifold pressure for all units fueled by L.P./propane gas at all altitudes is 10.0" w.c. See figures 27, 28 and 29 for the location of the manifold pressure adjustment screws.

High Altitude Information

NOTE - In Canada, certification for installations at elevations over 4500 feet (1372 m) is the jurisdiction of local authorities.

Manifold pressure for all units fueled by natural gas at all altitudes is 3.5" w.c. Manifold pressure for all units fueled by L.P./propane gas at all altitudes is 10.0" w.c.

NOTE - A natural to L.P. propane gas changeover kit is necessary to convert this unit. L.P. conversion kit 25W20 is used with all units installed at altitudes up to 7,500 feet. L.P. conversion kit 25W21 is used with all units installed at altitudes from 7,501 to 10,000 feet above sea level. Refer to the changeover kit installation instruction for the conversion procedure.

NOTE - Units fueled by natural gas and installed at altitudes of 7501-10,000 feet above sea level require installation of a high altitude orifice kit (59M17).

The combustion air pressure switches are factory-set and require no adjustment. The existing unit pressure switch must be replaced by pressure switch 56L32 for G50UH(X) units installed at altitudes from 7,501 to 10,000 feet above sea level.

Other Unit Adjustments

Primary and Secondary Limits

The primary limit is located on the heating compartment vestibule panel. The secondary limits (if equipped) are located in the blower compartment, attached to the back side of the blower. These limits are factory set and require no adjustment.

Flame Rollout Switches (Two)

These manually reset switches are located on (or inside of) the burner box. If tripped, check for adequate combustion air before resetting.

Pressure Switch

The pressure switch is located in the heating compartment adjacent to the combustion air inducer. This switch checks for proper combustion air inducer operation before allowing ignition trial. The switch is factory-set and requires no adjustment.

Temperature Rise

Place the unit into operation with a heating demand. After supply and return air temperatures have stabilized, check the temperature rise. If necessary, adjust the blower speed to maintain the temperature rise within the range shown on the unit nameplate. Increase the blower speed to decrease the temperature. Decrease the blower speed to increase the temperature rise. Failure to do adjust the temperature rise may cause erratic limit operation.

Fan Control

Heating Mode -- The fan on delay of 45 seconds is not adjustable. The fan off delay (amount of time that the blower operates after the heat demand has been satisfied) may be adjusted by setting S1 switches 1 and 2 located on the integrated control. The unit is shipped with a factory fan off setting of 90 seconds. The fan off delay affects comfort and is adjustable to satisfy individual applications. Adjust the fan off delay to achieve a supply air temperature between 90° and 110°F at the exact moment that the blower is de-energized. Longer off delay settings provide lower return air temperatures; shorter settings provide higher return air temperatures. See figure 25.

Cooling Mode -- The cooling mode fan off delay (amount of time that the blower operates after the cooling demand has been satisfied) may be adjusted by setting S1 switch 3 located on the SureLight® control. In the off position, the cooling fan off delay is 2 seconds. In the on position, the cooling fan off delay is 45 seconds. See figure 25.

Thermostat Heat Anticipation

Set the heat anticipator setting (if adjustable) according to the amp draw listed on the wiring diagram that is attached to the unit.

Electrical

- 1 - Check all wiring for loose connections.
- 2 - Check for the correct voltage at the furnace (furnace operating).
- 3 - Check amp-draw on the blower motor.
Motor Nameplate _____ Actual _____

NOTE - Do not secure the electrical conduit directly to the air ducts or structure.

Blower Speeds

NOTE - CFM readings are taken external to unit with a dry evaporator coil and without accessories.

- 1 - Turn off electrical power to furnace.
- 2 - Remove blower access panel.
- 3 - Disconnect existing speed tap at control board speed terminal.

NOTE - Termination of any unused motor leads must be insulated.

- 4 - Refer to blower speed selection chart on unit wiring diagram for desired heating or cooling speed.
- 5 - Connect selected speed tap at control board speed terminal.
- 6 - Resecure blower access panel.
- 7 - Turn on electrical power to furnace.

Electronic Ignition

The SureLight® integrated control has an added feature of an internal Watchguard control. The feature serves as an automatic reset device for ignition control lockout caused by ignition failure. After one hour of continuous thermostat demand for heat, the Watchguard will break and remake thermostat demand to the furnace and automatically reset the control to begin the ignition sequence.

Flue And Chimney

- 1 - Check flue pipe, chimney and all connections for tightness and to make sure there is no blockage.
- 2 - Check unit for proper draft.
- 3 - Is pressure switch closed? Obstructed flue will cause unit to shut off at pressure switch. Check flue and outlet for blockages.

- 4 - Reset manual flame rollout switches on burner box cover.

Failure To Operate

If the unit fails to operate, check the following:

- 1 - Is the thermostat calling for heat?
- 2 - Are access panels securely in place?
- 3 - Is the main disconnect switch closed?
- 4 - Is there a blown fuse?
- 5 - Is the filter dirty or plugged? Dirty or plugged filters will cause the limit control to shut the unit off.
- 6 - Is gas turned on at the meter?
- 7 - Is the manual main shut-off valve open?
- 8 - Is the internal manual shut-off valve open?
- 9 - Is the unit ignition system in lock out? If the unit locks out again, inspect the unit for blockages.

Blower Performance Data

NOTES - All air data is measured external to unit with 1 in. cleanable filter (not furnished - field provided) in place. Air volume based on bottom air return air. Actual air volume may vary on side return air applications.

G50UH-24A-045 PERFORMANCE

External Static Pressure in. w.g.	Air Volume / Watts at Various Blower Speeds					
	High		Medium		Low	
	cfm	Watts	cfm	Watts	cfm	Watts
0.00	1090	460	905	390	725	300
0.10	1065	445	895	385	710	295
0.20	1030	425	890	375	690	290
0.30	995	410	860	365	665	280
0.40	960	395	840	350	650	270
0.50	910	380	795	335	610	260
0.60	840	355	750	315	540	245
0.70	770	340	665	295	490	235
0.80	660	315	555	275	420	225
0.90	560	295	480	260	355	210

G50UH-24A-070 PERFORMANCE

External Static Pressure in. w.g.	Air Volume / Watts at Various Blower Speeds					
	High		Medium		Low	
	cfm	Watts	cfm	Watts	cfm	Watts
0.00	1075	445	905	375	730	290
0.10	1065	440	895	370	720	285
0.20	1055	430	885	360	710	280
0.30	1030	415	875	355	690	270
0.40	1010	400	860	350	675	270
0.50	975	390	840	340	660	265
0.60	940	375	805	325	640	255
0.70	890	360	755	305	605	240
0.80	830	340	700	285	565	225
0.90	765	305	640	265	515	205

G50UH-36A-070 PERFORMANCE

External Static Pressure in. w.g.	Air Volume / Watts at Various Blower Speeds							
	High		Medium-High		Medium-Low		Low	
	cfm	Watts	cfm	Watts	cfm	Watts	cfm	Watts
0.00	1500	705	1290	565	985	455	830	375
0.10	1450	680	1255	545	970	440	810	360
0.20	1400	655	1225	525	955	425	795	350
0.30	1340	630	1180	500	930	405	780	335
0.40	1285	610	1140	475	900	390	745	325
0.50	1215	580	1080	450	865	375	705	310
0.60	1150	560	1015	430	810	355	655	290
0.70	1060	535	940	405	730	330	585	270
0.80	955	515	800	370	655	305	480	260
0.90	785	475	605	325	585	270	410	255

G50UH-36B-090 PERFORMANCE

External Static Pressure in. w.g.	Air Volume / Watts at Various Blower Speeds							
	High		Medium-High		Medium-Low		Low	
	cfm	Watts	cfm	Watts	cfm	Watts	cfm	Watts
0.00	1500	720	1255	595	1040	460	900	370
0.10	1465	685	1240	570	1035	445	890	360
0.20	1435	660	1225	545	1030	435	880	350
0.30	1400	630	1200	520	1020	415	870	340
0.40	1345	595	1170	495	1000	400	855	330
0.50	1300	575	1135	475	965	380	830	300
0.60	1235	545	1080	445	930	360	780	290
0.70	1165	510	1020	415	870	340	740	280
0.80	1080	480	940	385	800	315	670	260
0.90	985	445	840	355	710	290	600	245

NOTES - All air data is measured external to unit with 1 in. cleanable filter (not furnished - field provided) in place.
 Air volume based on bottom air return air. Actual air volume may vary on side return air applications.

G50UH-36C-110 PERFORMANCE

External Static Pressure in. w.g.	Air Volume / Watts at Various Blower Speeds							
	High		Medium-High		Medium-Low		Low	
	cfm	Watts	cfm	Watts	cfm	Watts	cfm	Watts
0.00	1555	715	1335	575	1085	460	925	365
0.10	1525	690	1320	545	1075	440	915	355
0.20	1490	670	1295	525	1065	420	900	340
0.30	1440	645	1260	495	1050	405	880	330
0.40	1385	615	1230	485	1030	390	865	320
0.50	1320	590	1190	460	995	375	835	300
0.60	1260	570	1135	430	960	355	815	295
0.70	1190	545	1075	410	915	345	775	285
0.80	1090	515	970	385	860	325	760	280
0.90	975	485	880	360	790	305	705	275

G50UH-48C-110 PERFORMANCE

External Static Pressure in. w.g.	Air Volume / Watts at Various Blower Speeds							
	High		Medium-High		Medium-Low		Low	
	cfm	Watts	cfm	Watts	cfm	Watts	cfm	Watts
0.00	2015	895	1620	780	1340	640	1150	525
0.10	1965	850	1610	745	1340	640	1150	525
0.20	1895	805	1600	710	1335	615	1150	525
0.30	1820	765	1580	675	1330	590	1145	515
0.40	1740	725	1530	635	1320	560	1140	490
0.50	1665	695	1475	600	1285	525	1120	470
0.60	1575	650	1405	555	1230	490	1075	445
0.70	1475	610	1310	515	1165	470	1015	415
0.80	1350	560	1210	485	1080	430	930	380
0.90	1210	520	1070	430	870	365	740	325

G50UH-48B-090 PERFORMANCE

External Static Pressure in. w.g.	Air Volume / Watts at Various Blower Speeds							
	High		Medium-High		Medium-Low		Low	
	cfm	Watts	cfm	Watts	cfm	Watts	cfm	Watts
0.00	1970	790	1810	735	1585	670	1340	565
0.10	1915	765	1760	695	1570	630	1325	540
0.20	1840	730	1700	620	1545	600	1320	520
0.30	1765	695	1640	625	1490	565	1295	500
0.40	1695	670	1570	595	1440	540	1260	480
0.50	1600	635	1490	560	1360	505	1195	450
0.60	1505	600	1400	530	1285	480	1140	425
0.70	1395	565	1265	485	1170	440	990	380
0.80	1250	520	1100	445	975	390	905	355
0.90	1005	460	870	385	900	365	810	325

G50UH-48C-135 PERFORMANCE

External Static Pressure in. w.g.	Air Volume / Watts at Various Blower Speeds							
	High		Medium-High		Medium-Low		Low	
	cfm	Watts	cfm	Watts	cfm	Watts	cfm	Watts
0.00	2075	820	1800	710	1425	570	1115	435
0.10	1990	790	1765	675	1420	545	1125	430
0.20	1905	745	1715	645	1405	525	1120	420
0.30	1825	715	1650	610	1375	505	1105	405
0.40	1740	680	1585	580	1355	485	1090	390
0.50	1640	645	1495	545	1300	455	1050	370
0.60	1540	615	1420	515	1225	430	1000	355
0.70	1420	575	1310	475	1140	400	935	330
0.80	1260	520	1155	425	1025	365	865	315
0.90	1125	495	1010	385	880	330	750	285

NOTES - All air data is measured external to unit with 1 in. cleanable filter (not furnished - field provided) in place.

G50UH-60C-110 PERFORMANCE

External Static Pressure in. w.g.	Air Volume / Watts at Different Blower Speeds															
	Bottom Return Air, Side Return Air with Optional RAB Return Air Base, Return Air from Both Sides or Return Air from Bottom and One Side.						Single Side Return Air - Air volumes in bold require field fabricated transition to accommodate 20 x 25 x 1 in. air filter in order to maintain proper air velocity.									
	High		Medium-High		Medium-Low		Low		High		Medium-High		Medium-Low		Low	
	cfm	Watts	cfm	Watts	cfm	Watts	cfm	Watts	cfm	Watts	cfm	Watts	cfm	Watts	cfm	Watts
.00	2655	1407	2370	1063	2085	894	1665	679	2430	1309	2245	1006	1910	843	1635	686
.10	2580	1376	2350	1043	2065	875	1650	667	2355	1277	2190	978	1905	817	1620	677
.20	2500	1346	2305	1012	2045	849	1645	662	2280	1242	2140	950	1885	797	1610	667
.30	2410	1305	2230	978	2010	820	1640	649	2205	1218	2075	924	1860	782	1605	655
.40	2320	1270	2165	947	1940	786	1625	634	2130	1189	2005	905	1815	752	1595	636
.50	2225	1235	2090	914	1895	763	1610	622	2045	1159	1920	864	1750	726	1565	619
.60	2130	1205	2000	880	1840	740	1570	603	1955	1132	1850	840	1700	705	1525	605
.70	2030	1155	1915	851	1760	709	1535	590	1860	1105	1760	817	1610	674	1475	582
.80	1925	1123	1820	823	1670	681	1475	566	1755	1067	1670	789	1540	654	1395	560
.90	1795	1078	1690	788	1560	655	1395	537	1645	1033	1575	763	1445	627	1325	540

G50UH-60D-135 PERFORMANCE

External Static Pressure in. w.g.	Air Volume / Watts at Different Blower Speeds															
	Bottom Return Air, Side Return Air with Optional RAB Return Air Base, Return Air from Both Sides or Return Air from Bottom and One Side.						Single Side Return Air - Air volumes in bold require field fabricated transition to accommodate 20 x 25 x 1 in. air filter in order to maintain proper air velocity.									
	High		Medium-High		Medium-Low		Low		High		Medium-High		Medium-Low		Low	
	cfm	Watts	cfm	Watts	cfm	Watts	cfm	Watts	cfm	Watts	cfm	Watts	cfm	Watts	cfm	Watts
.00	2715	1407	2255	1070	1910	850	1660	674	2455	1336	2170	1019	1850	829	1555	673
.10	2640	1403	2250	1030	1900	834	1645	668	2380	1299	2140	974	1840	812	1550	664
.20	2540	1355	2245	1006	1890	821	1630	665	2305	1266	2105	947	1830	791	1545	656
.30	2480	1319	2200	975	1890	781	1625	656	2235	1234	2045	914	1820	774	1540	642
.40	2390	1282	2155	940	1885	775	1615	642	2160	1240	1985	886	1800	755	1540	628
.50	2320	1251	2085	904	1860	758	1605	631	2065	1170	1925	863	1745	726	1535	614
.60	2205	1210	2020	876	1815	731	1595	611	1990	1146	1870	844	1700	706	1505	599
.70	2080	1161	1935	839	1760	707	1545	588	1895	1111	1775	808	1655	689	1465	573
.80	2010	1122	1855	810	1690	679	1495	568	1805	1074	1680	779	1565	656	1425	562
.90	1880	1071	1755	781	1585	646	1430	545	1695	1042	1590	752	1480	630	1335	533

NOTES - All air data is measured external to unit with 1 in. cleanable filter (not furnished - field provided) in place.

G50UH-60D-155 PERFORMANCE

External Static Pressure in. w.g.	Air Volume / Watts at Different Blower Speeds															
	Bottom Return Air, Side Return Air with Optional RAB Return Air Base, Return Air from Both Sides or Return Air from Bottom and One Side.								Single Side Return Air - Air volumes in bold require field fabricated transition to accommodate 20 x 25 x 1 in. air filter in order to maintain proper air velocity.							
	High		Medium-High		Medium-Low		Low		High		Medium-High		Medium-Low		Low	
	cfm	Watts	cfm	Watts	cfm	Watts	cfm	Watts	cfm	Watts	cfm	Watts	cfm	Watts	cfm	Watts
.00	2670	1386	2325	1048	1970	857	1700	706	2410	1282	2175	987	1870	833	1620	675
.10	2580	1342	2320	1045	1965	842	1690	696	2335	1257	2140	956	1860	810	1610	667
.20	2510	1311	2255	985	1960	817	1640	662	2255	1225	2085	918	1855	788	1605	658
.30	2425	1277	2210	953	1955	803	1635	649	2205	1200	2025	896	1830	764	1600	647
.40	2345	1246	2150	922	1925	778	1630	633	2120	1164	1975	874	1795	742	1595	628
.50	2255	1217	2095	897	1890	752	1615	618	2040	1131	1905	847	1745	731	1575	618
.60	2170	1182	2010	863	1840	733	1590	605	1955	1103	1835	820	1695	698	1540	601
.70	2090	1139	1925	833	1785	708	1550	588	1870	1069	1760	792	1635	673	1465	568
.80	1895	1106	1840	806	1710	683	1500	571	1770	1041	1670	763	1560	646	1415	548
.90	1855	1064	1740	776	1620	655	1430	551	1660	1006	1585	740	1480	629	1345	527

Service

⚠ WARNING

Disconnect power before servicing unit.

⚠ CAUTION

Label all wires prior to disconnection when servicing controls. Wiring errors can cause improper and dangerous operation. Verify proper operation after servicing.

At the beginning of each heating season, a licensed professional technician (or equivalent) should check the system as follows:

Blower

Check the blower wheel for debris and clean if necessary. The blower motors are prelubricated for extended bearing life. No further lubrication is needed.

⚠ WARNING

The blower access panel must be securely in place when the blower and burners are operating. Gas fumes, which could contain carbon monoxide, can be drawn into living space resulting in personal injury or death.

Filters

All G50UH(X) filters are installed external to the unit. Filters should be inspected monthly. Clean or replace the filters when necessary to ensure that the furnace operates properly. Replacement filters must be rated for high velocity airflow. Table 1 lists recommended filter sizes.

Flue And Chimney

Check the flue pipe, chimney and all connections for tightness and to make sure there is no blockage.

Electrical

- 1 - Check all wiring for loose connections.
- 2 - Check for the correct voltage at the furnace (furnace operating).
- 3 - Check amp-draw on the blower motor.
Motor Nameplate _____ Actual _____

Cleaning the Heat Exchanger and Burners

NOTE - Use papers or protective covering in front of the furnace during cleaning.

Cleaning the heat exchanger requires a steel spring "snake," a reversible drill and a vacuum cleaner. The steel spring snake may be constructed by purchasing a 4 ft. long by 1/4 inch diameter steel wire cable and a 1/4 inch diameter wire brush. These items are available at a hardware store. Insert wire end of brush into the open end of the spring cable. Crimp the cable around the brush so that the brush is secured and will not come off during cleaning. Attach the other end of the cable to the reversible drill to complete the tool for cleaning the heat exchanger.

- 1 - Turn off both electrical and gas power supplies to furnace.
- 2 - Remove flue pipe and top cap from the unit. Label the pressure switch wires, then disconnect them.
- 3 - Remove the four screws that secure the combustion air inducer. Carefully remove the combustion air inducer to avoid damaging blower gasket. If gasket is damaged, it must be replaced to prevent leakage. See figure 30.

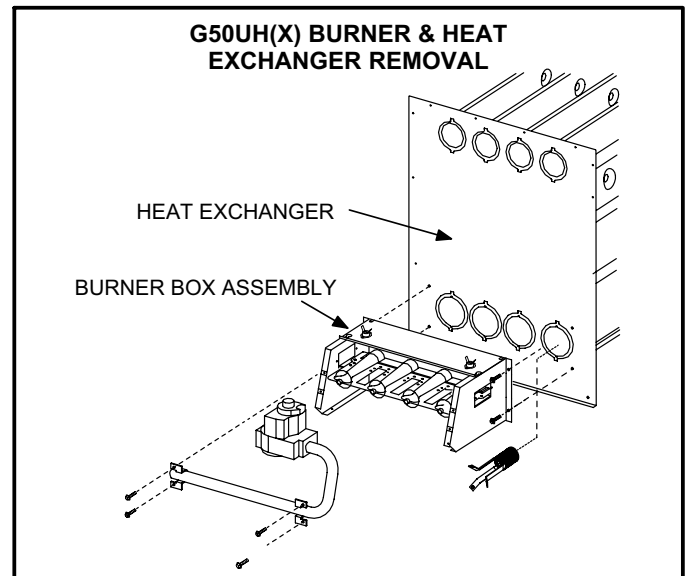

FIGURE 30

- 4 - Remove the collector box located behind the combustion air inducer. Be careful with the collector box gasket. If the gasket is damaged, it must be replaced to prevent leakage.
- 5 - Label the wires from gas valve and rollout switches, then disconnect them.
- 6 - Disconnect gas supply piping. Remove four screws securing the burner manifold assembly to the vestibule panel and remove the assembly from the unit.
- 7 - **NOx units only** - Remove the three screws that attach the NOx insert to the corbel at the entrance to each heat exchanger section. Carefully remove the NOx insert from each section. See figure 31.

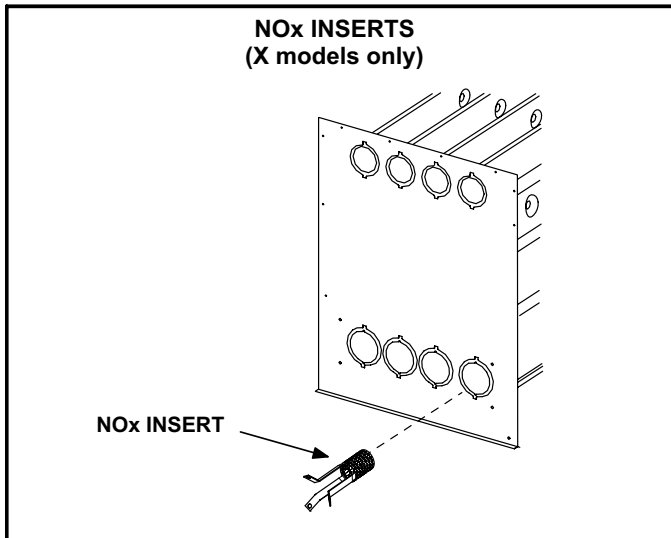

FIGURE 31

- 8 - Insert the brush end of cable snake into the top of one of the heat exchanger openings. **Do not force the cable into the heat exchanger.** Insert the cable and operate the drill on slow speed. Move the cable in and out of the heat exchanger section three or four times or until sufficient cleaning is accomplished. Reverse drill and slowly work the cable out of opening.
- 9- Repeat procedure for each heat exchanger section.
- 10- After each of the top heat exchanger sections has been cleaned, insert the brush end of the cable snake into the bottom openings of each of the heat exchanger sections and clean as described in step 8.
- 11- Remove the cable from the heat exchanger. Use a vacuum cleaner to remove debris knocked loose during cleaning.
- 12- Attach the exhaust end (positive pressure) of the vacuum cleaner to the top of the heat exchanger section. Any loose debris will be forced to the bottom of the heat exchanger section. Vacuum debris from bottom openings.
- 13- Replace collector box and combustion air inducer. Check gaskets for damage. Damaged gaskets must be replaced to avoid heat exchanger leaks. Replace all screws to the collector box and combustion air inducer. Failure to replace all screws may cause leaks.
- 14- To clean the burner, run a vacuum cleaner with a soft brush attachment over the face of burners. Visually inspect inside the burners and crossovers for any blockage caused by foreign matter. Remove any blockage.
- 15- **NOx Units** - Reattach the NOx inserts to the corbels at the entrance to each heat exchanger opening. See figure 31.
- 16- Replace burner/manifold assembly onto the vestibule panel.
- 17- Reconnect wires to pressure switch, roll-out switches, gas valve and combustion air inducer. Refer to unit wiring diagram.

- 18- Reconnect vent pipe to combustion air inducer outlet.
- 19- Reconnect gas supply piping.
- 20- Turn on power and gas supply to unit.
- 21- Set thermostat and check for proper operation.
- 22- Check all piping connections, factory and field, for gas leaks. Use a leak detecting solution or other preferred means.

⚠ CAUTION

Some soaps used for leak detection are corrosive to certain metals. Carefully rinse piping thoroughly after leak test has been completed. Do not use matches, candles, flame or other sources of ignition to check for gas leaks.

- 23- If a leak is detected, shut gas and electricity off and repair leak.
- 24- Repeat steps 23 and 24 until no leaks are detected.
- 25- Replace front access panel.

Planned Service

The service technician should check the following during an annual inspection. Power to the unit must be shut off for the service technician's safety.

Fresh air grilles and louvers (on the unit and in the room where the furnace is installed) - Must be open and unobstructed to provide combustion air.

Burners - Must be inspected for rust, dirt, or signs of water.

Vent pipe - Must be inspected for signs of water, damaged or sagging pipe, or disconnected joints.

Unit appearance - Must be inspected for rust, dirt, signs of water, burnt or damaged wires, or components.

Blower access door - Must be properly in place and provide a seal between the return air and the room where the furnace is installed.

Return air duct - Must be properly attached and provide an air seal to the unit.

Operating performance - Unit must be observed during operation to monitor proper performance of the unit and the vent system.

Combustion gases - Flue products must be analyzed and compared to the unit specifications.

Problems detected during the inspection may make it necessary to temporarily shut down the furnace until the items can be repaired or replaced.

Instruct the homeowners to pay attention to their furnace. Situations can arise between annual furnace inspections that may result in unsafe operation.

Repair Parts List

The following repair parts are available through Lennox dealers. When ordering parts, include the complete furnace model number listed on the CSA International nameplate -- Example: G50UH(X)-24A-045-8. **All service must be performed by a licensed professional installer (or equivalent), service agency, or gas supplier.**

Cabinet Parts

Upper access panel
Blower panel
Top cap

Control Panel Parts

Transformer
SureLight® ignition board
Door interlock switch
Circuit breaker

Blower Parts

Blower wheel
Motor
Motor mounting frame
Motor capacitor
Blower housing cutoff plate

Heating Parts

Flame Sensor
Heat exchanger assembly
Gas manifold
Combustion air inducer
Gas valve
Main burner cluster
Main burner orifices
Pressure switch
Ignitor
Primary limit control
Flame rollout switch
Secondary limit (not used on 24A-45-1)

Ignition Control Board Diagnostic Codes

DIAGNOSTIC CODES

Make sure to Identify LED'S Correctly.
Refer to Installation Instructions for control board layout.

DS1 (Red or Green)	DS2 (Green)	DESCRIPTION
SIMULTANEOUS SLOW FLASH	SIMULTANEOUS SLOW FLASH	Power on -- Normal operation. Also signaled during cooling and continuous fan.
SIMULTANEOUS FAST FLASH	SIMULTANEOUS FAST FLASH	Normal operation -- Signaled when heating demand initiated at thermostat.
SLOW FLASH	ON	Primary or secondary limit switch open. Limit must close within 3 minutes or unit goes into 1-hour Watchguard.
OFF	SLOW FLASH	Pressure switch open; OR: Blocked inlet/exhaust vent; OR: Condensate line blocked; OR: Pressure switch closed prior to activation of combustion air inducer.
ALTERNATING SLOW FLASH	ALTERNATING SLOW FLASH	Watchguard -- Burners failed to ignite, limit open longer than 3 minutes, or flame sense lost 5 times in one heating cycle.
SLOW FLASH	OFF	Flame sensed without gas valve energized.
ON	SLOW FLASH	Rollout switch open.
ON ON OFF	ON OFF ON	Circuit board failure or control wired incorrectly. Check 24-volt and 115-volt connections to board.
FAST FLASH	SLOW FLASH	Main power polarity reversed. Switch line and neutral. Improper main ground.
SLOW FLASH	FAST FLASH	Low flame signal. Check flame sensor.
ALTERNATING FAST FLASH	ALTERNATING FAST FLASH	The following conditions are sensed during the ignitor warm-up period only: 1) Improper main ground; 2) Broken ignitor; OR: Open ignitor circuit; 3) Line voltage below 75 volts.

*NOTE - Slow flash rate equals 1 Hz (one flash per second). Fast flash rate equals 3 Hz (three flashes per second).
Drop out flame sense current = 0.15 - 0.24 microAmps.*

SureLight® Troubleshooting: Heating Sequence of Operation

SURELIGHT® CONTROL HEATING SEQUENCE OF OPERATION

NORMAL HEATING MODE

ABNORMAL HEATING MODE

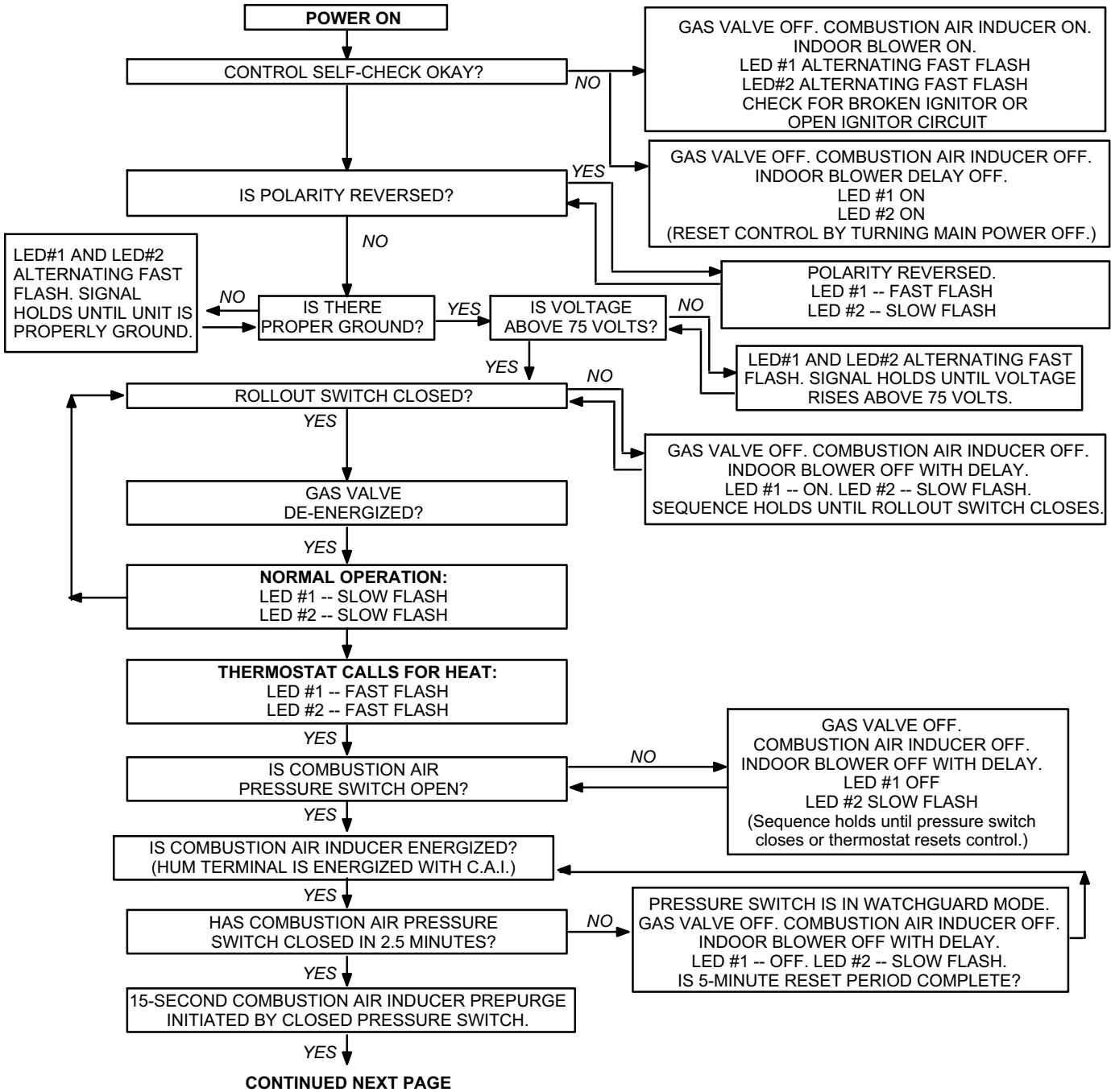

SureLight® Troubleshooting: Heating Sequence of Operation (Continued)

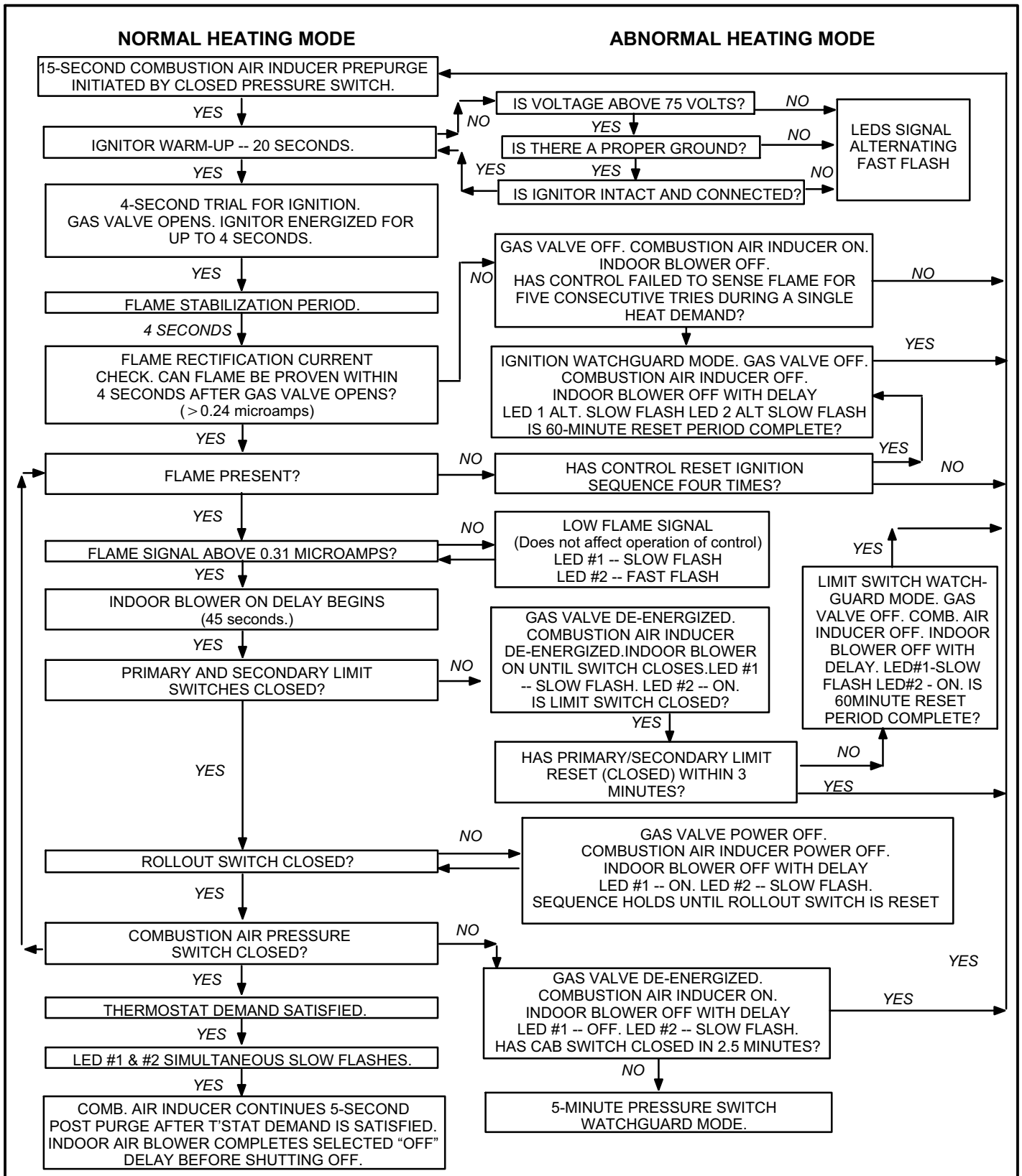

SureLight® Troubleshooting: Cooling Sequence of Operation

SURELIGHT® CONTROL COOLING SEQUENCE OF OPERATION

NORMAL COOLING MODE

ABNORMAL COOLING MODE

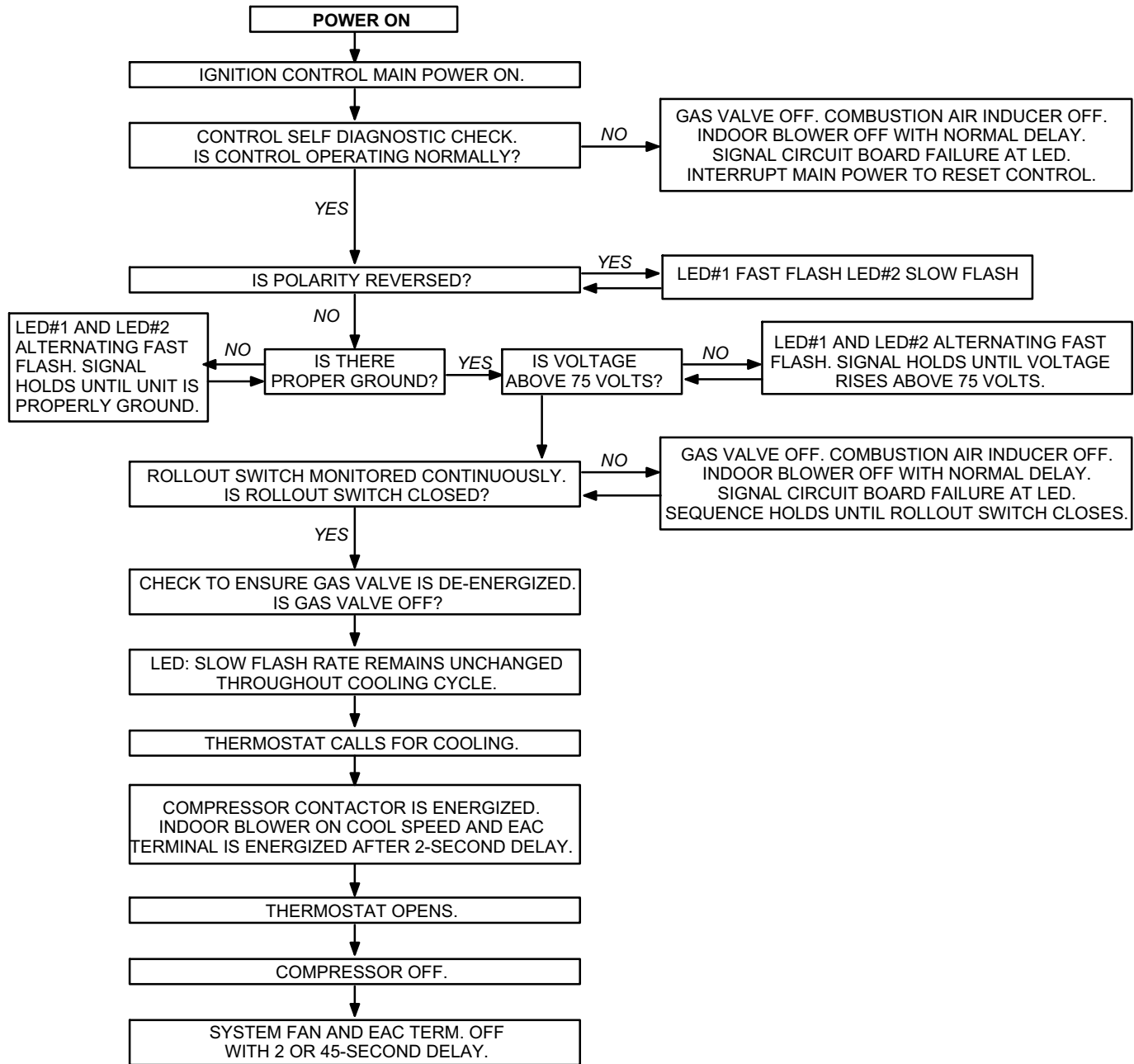

SureLight® Troubleshooting: Continuous Fan Sequence of Operation

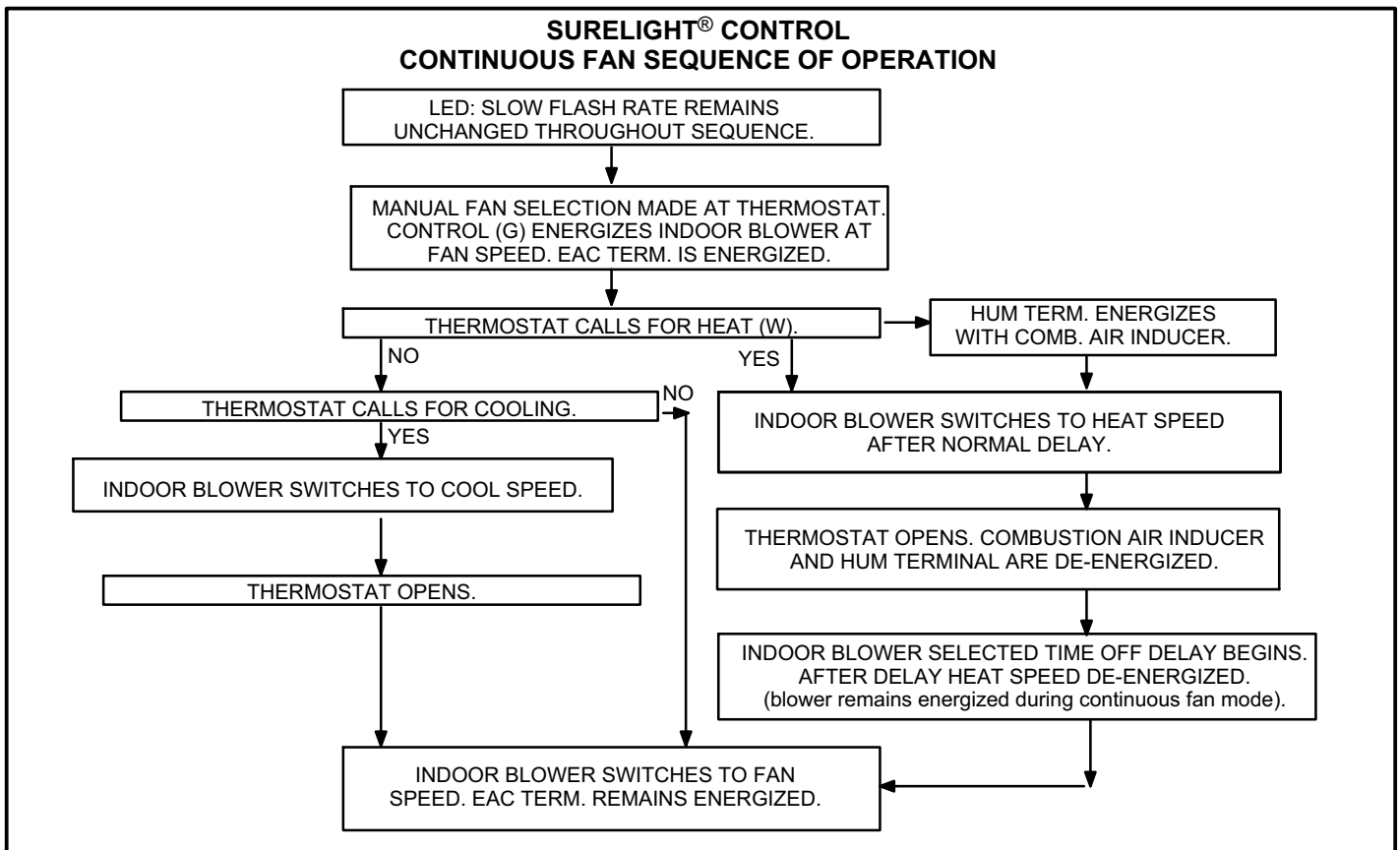

G50UH(X) Start-Up & Performance Check List

Job Name _____ Job No. _____ Date _____

Job Location _____ City _____ State _____

Installer _____ City _____ State _____

Unit Model No. _____ Technician _____

Serial No. _____

Heating Section

Electrical Connections Tight?

Supply Voltage _____ Blower Motor H.P. _____

Blower Motor Amps

Gas Piping Connections
Tight & Leak-Tested?

Fuel Type: Natural Gas?

LP/Propane Gas?

Furnace Btu Input _____

Line Pressure _____

Regulator Pressure _____ w.c. - Nat.: _____ w.c. - LP/Propane

Flue Connections Tight?

Proper Draft?

Combustion Gas Tested? CO₂ CO

Fan Control Setting
(45 Seconds Fixed On) _____

Temperature Rise _____

Fan Control Off Setting

Filter Clean & Secure?

Vent Clear?

Thermostat

Calibrated?

Heat Anticipator Properly Set?

Level?